

# Latest developments in ammonia production technology

RESEARCH | TECHNOLOGY | CATALYSTS



By Svend Erik Nielsen

Presented at "FAI International Conference in Fertiliser Technology"

12-13 April, 2007, New Delhi

by

Svend Erik Nielsen  
Haldor Topsøe A/S Lyngby, Denmark

## Abstract

*Many Indian ammonia plants struggle with high feedstock prices. In order to survive in the competition from new plants in areas with low gas cost, many plant owners of existing plants have decided to revamp their plants to reduce the energy consumption and/or increase the capacity. New developments are needed in order to fulfil these needs of the market.*

*This paper will highlight some of the developments made that are suitable to be implemented in revamp jobs. Furthermore, these developments are also important for design of new very large capacity ammonia plants, and process schemes for a 4000 and a 5000 MTPD ammonia plants will be covered, including an attractive option, which has been in full-scale commercial operation since January 2003, the proprietary and patented Haldor Topsøe Exchange Reformer (HTER).*

## 1 Introduction

A number of developments made by Topsøe will be described, which is relevant for both revamp projects and new plants. In the following paper some of the revamp projects undertaken by Topsøe in India will be introduced, and also a novel feature, the HTER (Haldor Topsøe Exchange Reformer) implemented in the industry in a synthesis gas plant in South Africa, will be mentioned. Furthermore, process schemes to be used for very large ammonia plant capacities in the order of 4000 to 5000 MTPD will be presented

## 2 Latest developments in ammonia process technology

New advanced technology relevant for new plants or revamp projects is available including new process concepts, improved or new equipment designs, and more effective catalysts, and new knowledge about the limits acceptable in operation of various units. The extent to which advanced technology can be applied to a specific project varies depending upon the specific situation.

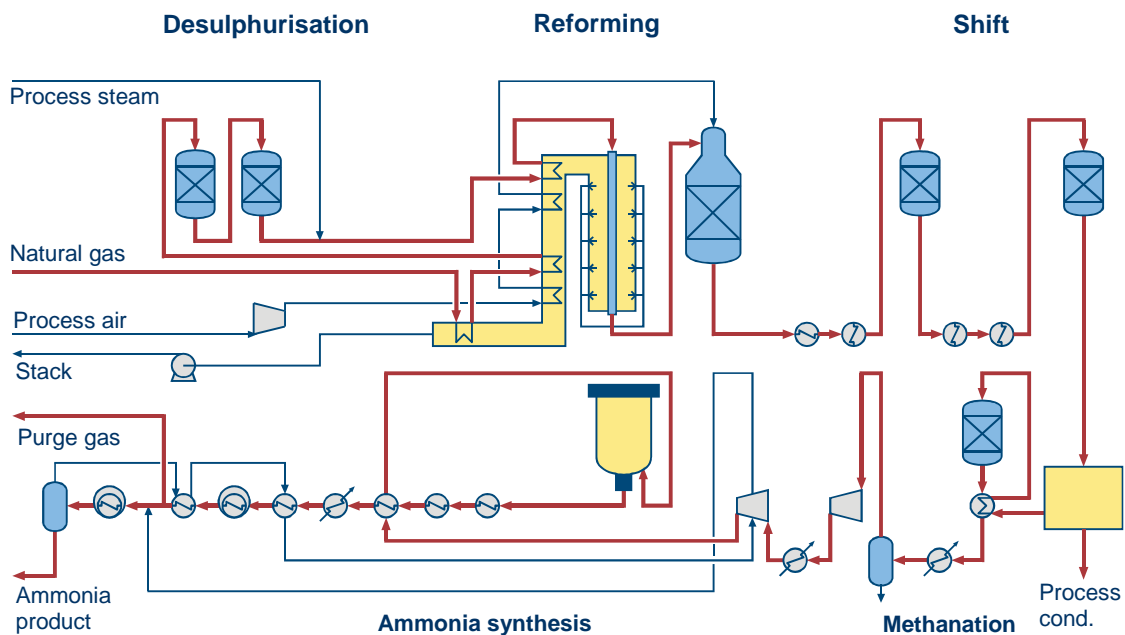

Figure 1. Current scheme

### 2.1 Current scheme

The Topsøe low energy ammonia process shown in Figure 1 features a well-proven concept – desulphurisation, primary and secondary reforming, two-step shift conversion, carbon dioxide removal, methanation, compression, ammonia synthesis, and product recovery.

The process layout is identical to the scheme proposed for decades, but the performance has significantly improved due to improvements in catalysts and new developments in equipment designs

### 3 New developments

Two main areas have significant impact on the performance and cost of an ammonia plant – the reforming section and the ammonia synthesis section. The following items will be covered in this paper:

- High flux primary reformer with prereformer
- HTER-p (Haldor Topsøe Exchange Reformer)
- S-300 and S-50 converters

In particular the design and performance of the side-fired primary reformer has been significantly improved. This has been possible due to the availability of better tube materials with higher strength. Better tube materials permit a reduction in tube wall thickness, thus reducing the level of thermal stress in the tube wall, which again will give potentials for increased lifetime of the tubes. Very high heat flux can be accepted in a modern type reformer, and with a prereformer in front of the reformer the acceptable heat flux can be increased even further.

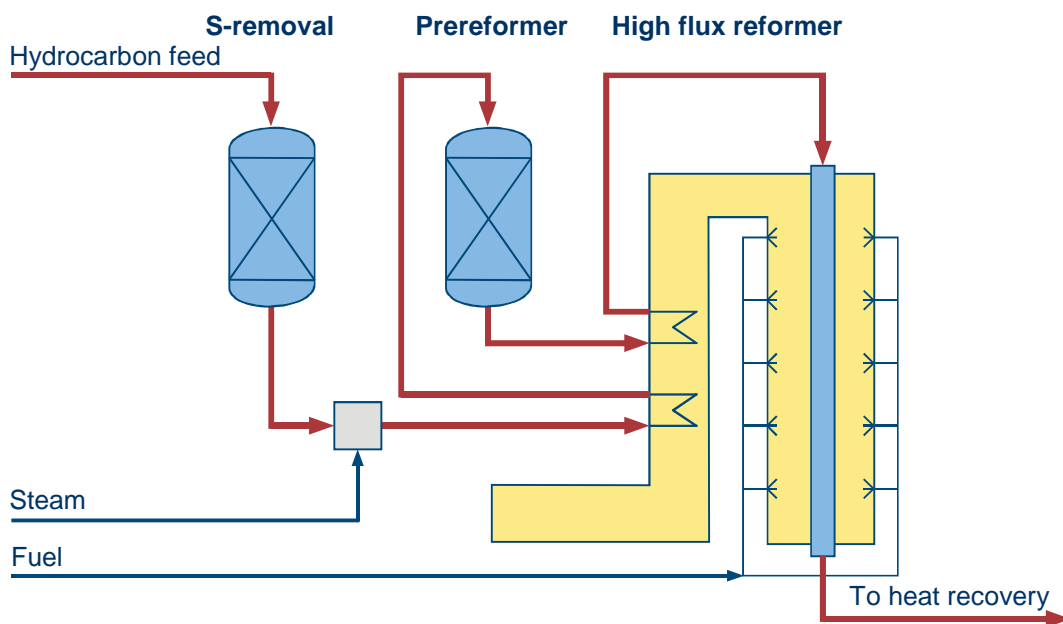

Figure 2. Prereformer unit

#### 3.1 Prereforming

Adiabatic prereforming can be used for steam reforming of feedstocks ranging from natural gas to heavy naphtha. In the prereformer all higher hydrocarbons are converted into a mixture of carbon oxides, hydrogen and methane. When a prereformer is

installed as shown in Figure 2, the primary reformer has to reform methane only, and at the same time at sulphur free conditions, because the prereforming catalyst will pick up any sulphur components in the feed quantitatively. The sulphur free operation is one of the reasons for allowing a much higher heat flux in the reformer.

The prereformed feed can be reheated to 650°C before entering the primary reformer. This will result in reduced firing in the primary reformer, and thereby a reduced fuel consumption. When the hot flue gas is used to reheat the reformer feed, the amount of heat available for HP steam production is reduced. This will overall result in a reduced HP steam production in the ammonia plant.

In general, the reformer size can be reduced up to 25% in a natural gas based plant by incorporating a prereformer.

### 3.2 HTER-p

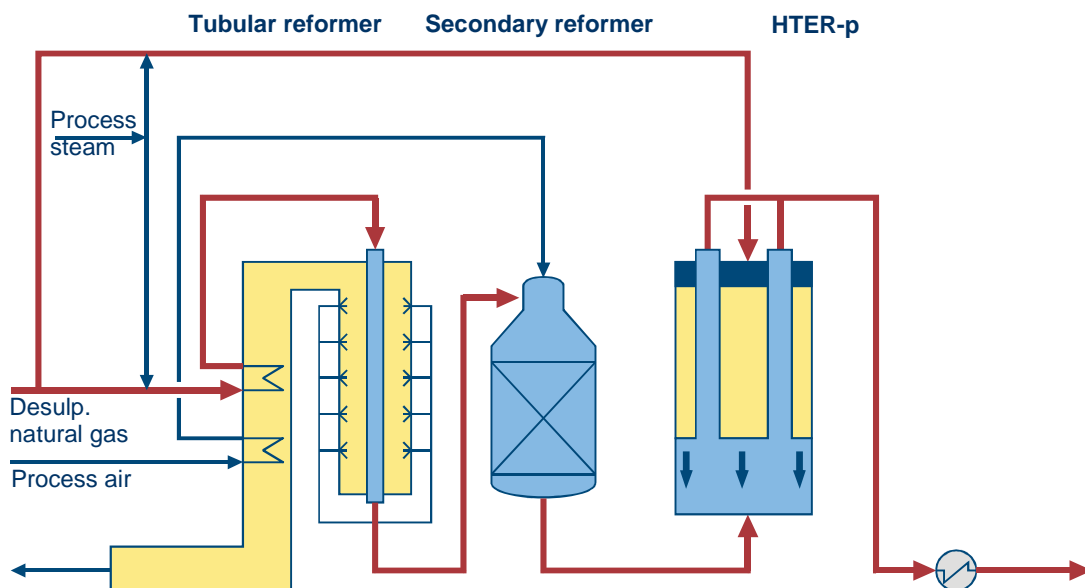

Figure 3. HTER-p

Another feature that can be used to reduce the size of the primary reformer, and at the same time reduce the HP steam production, is the HTER-p (Haldor Topsøe Exchange Reformer). Please see Figure 3. This is a new feature, initially developed for use in synthesis gas plants. In ammonia plants this unit is operated in parallel with the primary reformer, and that is why the name is HTER-p.

The HTER-p is heated by the exit gas from the secondary reformer, and thereby the waste heat normally used for HP steam production can be used for the reforming process down to typically 750–850°C, depending upon actual requirements. Operating conditions in the HTER-p are adjusted independently of the primary reformer in order to get the optimum performance of the overall reforming unit. Typically up to around 20% of the natural gas feed can in this way by-pass the primary reformer.

### 3.3 S- 350 ammonia synthesis loop

In the ammonia synthesis section, the 3-bed radial flow converter – the S-300 – has been developed and commercialised as an improved version of the work horse - the S-200. A highly efficient combination of the S-300 converter and the one-bed S-50 converter – the S-350 synthesis loop – has been developed, which is applicable for new plants as well as for revamp jobs.

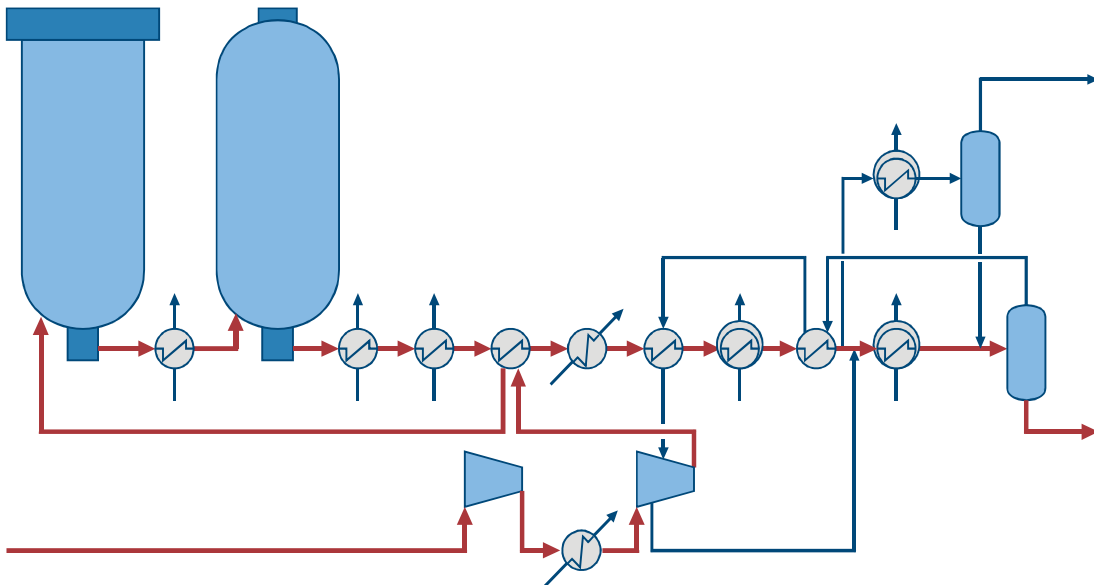

Figure 4. S-350 ammonia synthesis loop

Figure 4 above describes a typical Topsøe ammonia synthesis loop.

As can be seen, the loop comprises two ammonia converters, i.e. a S-300 followed by a S-50 converter. The S-50 converter is a single bed radial flow converter, which is added downstream of the main converter to increase the ammonia conversion, and at the same time to improve the steam generation. By having two converters, the heat of reaction after the last bed in the first converter can be utilised for boiling or superheating of HP steam, and the two converter configuration can be used as a mean to close the overall plant steam balance, if the waste heat available for boiler feed water preheat and boiling of steam is not in balance.

#### **4 Recent revamp experience including the S-50 converter**

The new features mentioned above can be implemented in new plants as well as in revamp projects. Please below find a list of some of the revamp projects done by Topsøe in India recently:

- IFFCO, Kalol, natural gas-based plant started up in 1975 designed by Kellogg
- RCF, Trombay V natural gas-based plant started up in 1980, designed by Topsøe
- IFFCO, Phulpur I, naphtha-based plant started up in 1980 designed by Kellogg
- IFFCO, Aonla I, natural gas-based plant started up in 1988 designed by Topsøe
- IFFCO, Aonla II, mixed feed-based plant started up in 1996 designed by Topsøe
- IFFCO, Phulpur II, naphtha-based plant started up in 1997 designed by Topsøe
- NFL, Vijaipur I, natural gas-based plant started up in 1987 designed by Topsøe

A few of these projects will be mentioned below as examples of revamp projects where some of the developments have been introduced. For details about the other revamp projects, please see ref (1) and ref (2).

#### **4.1 Energy conservation projects**

##### **4.1.1 IFFCO, Kalol**

The project for IFFCO, Kalol is an energy saving project. The plant has actually been revamped by Topsøe earlier, where a prereformer was installed to process naphtha feed. However, this time the revamp concerns energy saving, and it was decided by IFFCO to implement the energy saving project in two phases, in order to get immediate benefits. The following revamp options have been installed in a phased manner:

##### **Phase I**

- New LTS guard, inlet separator and BFW preheaters.
- Revamping of the existing CO<sub>2</sub> removal system to a two-stage aMDEA process - including new LP, HP flash vessels, a new absorber, and a recycle MDEA compressor.

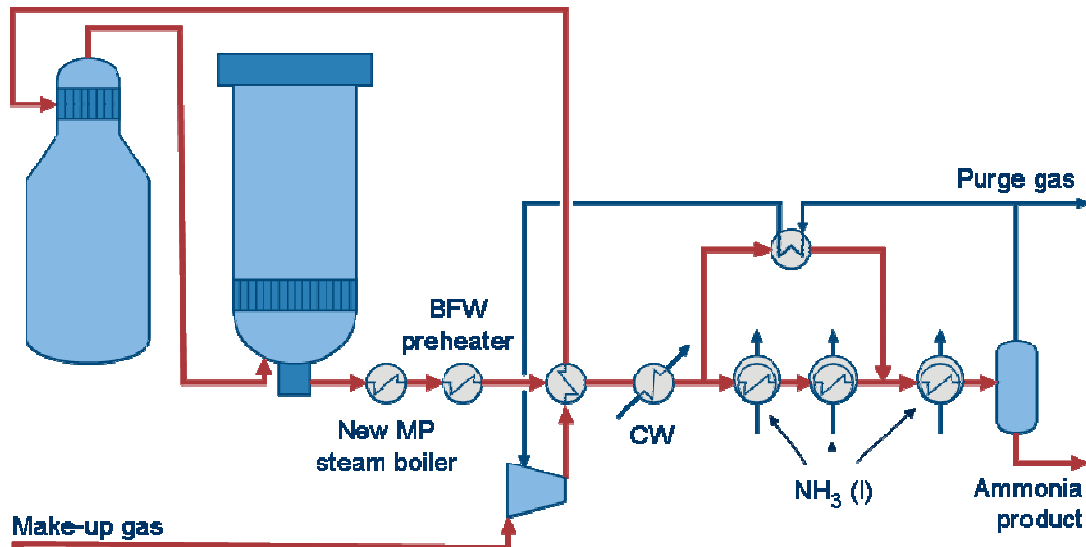

Figure 5. Layout of synthesis loop in M.W. Kellogg-designed plant with S-50 converter

### Phase II

- Installation of a S-50 radial flow converter with internal electric start-up heater and lower heat exchanger, and MP waste heat boiler in the loop in series with the existing converter
- Drying of make-up gas and synthesis loop re-piping
- Replacement of HP and LP rotors in synthesis gas compressor with kick-back cooler for synthesis gas compressor recycle stage
- Installation of a new boiler feed water coil in the waste heat section of the primary reformer
- Modification of ID fan turbine

#### 4.1.2 S-50 converter – Kalol plant

The original ammonia synthesis loop contains an existing ammonia converter unit with built-in feed/effluent exchanger. After the revamp, the exit gas from the existing converter is sent direct to the new S-50 converter at a temperature of approx. 325°C. After the S-50 converter a new MP steam boiler is installed. See Figure 5.

As the inlet temperature to the S-50 converter is lower than the required inlet temperature to the catalyst bed, an S-50 converter with a lower heat exchanger is applied.

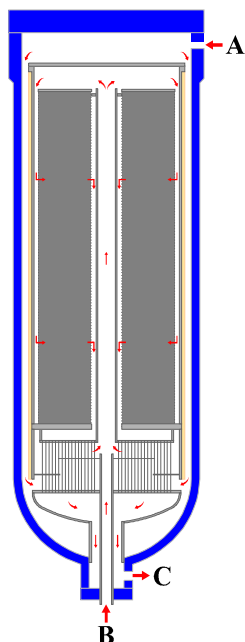

The S-50 converter consists of a full opening closure pressure vessel and a converter basket. The converter basket consists of a catalyst bed and a feed/effluent heat exchanger (lower heat exchanger). See Figure 6 for details.

The main part of the gas is introduced into the converter through the main inlet in the top of the converter (A) and passes downwards through the outer annulus between the basket and the pressure shell, keeping the latter cooled. It passes to the shell side of the feed-effluent exchanger, where it is heated to reaction temperature by heat exchange with the converter effluent leaving the catalyst bed.

The remaining part of the gas, the cold shot gas, is introduced through the inlet in the bottom of the converter (B). It mixes with the main inlet gas having passed the shell side of the heat exchanger, and the mixed gas passes to the top of the converter through the transfer pipe in the centre of the catalyst bed. The amount of cold shot gas determines the inlet temperature to the catalyst bed.

**Figure 6.** S-50 converter with lower heat exchanger

At the top of the converter the gas passes to the inlet panels of the catalyst bed and through the catalyst bed in radial inward direction to the annulus between the bed and the central transfer pipe.

The effluent from the catalyst bed passes the tube side of the heat exchanger, thereby heating the feed gas to the reaction temperature, and flows to the converter outlet (C).

The project was started in November 2003. Most of the new equipment was installed while the plant was running. The major modification was to install the new absorber and the flash vessels. During the normal turn around in March/April 2005, phase I of the project were implemented, and the final installation was done in particular with the stripper arrangement and reboilers. In the turn around during May 2006, the phase II items were installed in only 21 days. After commissioning of the new items the plant has been started up, and the test run was successfully passed by the end of 2006.

#### 4.1.3 IFFCO, Kalol energy saving and payback period

The total reduction in energy is about 10%. Simple payback time period is 4.8 years.

#### 4.2 RCF, Trombay V

The project for RCF, Trombay V is an energy saving project. The plant is more than 25 years old, and RCF decided to revamp the plant by incorporating a number of new features. The revamp project is fairly extensive, and the following revamp features have been incorporated:

- Modification of primary reformer to single row catalyst tubes and addition of one more section in each chamber
- Installation of combustion air preheater in reformer convection section in lieu of the BFW preheater
- Replacement of reformer burners by forced draught type
- Installation of new reforming catalyst
- Installation of new BFW preheater and separator downstream LT guard
- Installation of convection section in existing fired steam superheater with provision for feed gas preheating and combustion air preheating
- Replacement of burners in the fired steam superheater by forced draught type
- Installation of new 5-stage flash vessel (CO<sub>2</sub> removal) with ejectors and mechanical steam compressor (not yet commissioned)
- Installation of hydraulic turbine with generator on rich solution (not yet commissioned)
- Replacement of packing in CO<sub>2</sub> removal columns
- Installation of DMW preheater OH regenerator
- Installation of additional gas/gas heat exchanger (E 311 B)
- Replacement of existing process condensate stripping system by new MP stripping system
- Installation of additional process condensate pumps
- Spare HP BFW pump (P 701 A) to be driven by LP steam condensing turbine (not yet commissioned)
- Modification of process air compressor
- New synthesis gas compressor and turbine drive (not yet commissioned)
- Installation of S-50 converter downstream existing converter
- Installation of new loop boiler downstream new S-50 converter
- Replacement of existing cold flare by two hot flares, one for process gas and one for ammonia vapour
- New ammonia booster compressor, K 451 (not yet commissioned)
- New water cooler, E 503

The RCF, Trombay V revamp project started in March, 2004. Most of the options have been implemented during a long turnaround lasting for 12 weeks during May, June and July 2006. Only the new synthesis gas compressor with driver and the mechanical steam compressor are not yet started. These remaining items will be taken into operation after the scheduled turn around in April 2007.

Especially the modifications of the reformer have been very interesting. The old type “snake row” reformer has been converted to straight row, and a new section has been added to each of the chambers. Furthermore, the selfinspiring burners have been replaced by forced draft burners along with combustion air preheating. Also the fired steam heater has been extensively revamped, and a new convection section has been added in order to save energy. This section comprises natural gas preheating and combustion air preheating.

#### **4.2.1 RCF, Trombay V energy saving and payback period**

The total reduction in energy saving is approx. 19% due to implementation of the energy saving measures. Simple payback period is about 4.4 years.

## **5 Experience with installation of HTER (Haldor Topsøe Exchange Reformer)**

### **5.1 Industrial experience**

The first HTER has already been in successful operation for more than 4 years in a synthesis gas plant in South Africa, with Sasol Synfuels and seven more are currently in the engineering design phase. The HTER was installed to increase the reforming capacity of the plant. The revamped unit was ready for operation and start up in January 2003. Only 5 years had passed since the first basic ideas were exchanged about the project. During this period of time, the project went through pre-feasibility and feasibility studies including material screenings, etc., basic and detailed engineering as well as construction and commissioning. This remarkable achievement was possible only through a committed effort from the involved parties, Sasol Synfuels, Sasol Technology and Topsøe. Details of the industrial experience are given in ref (3). Figure 7 shows a picture of the HTER internals being lifted after arrival to the site.



**Figure 7.** HTER internal being installed

Figure 8 shows the layout of the reforming section after revamp. Since the initial start-up, no unforeseen stops were related to the HTER, and the HTER has been in continuous operation with the exception of planned shut-downs. This has led to a high availability factor (97%).

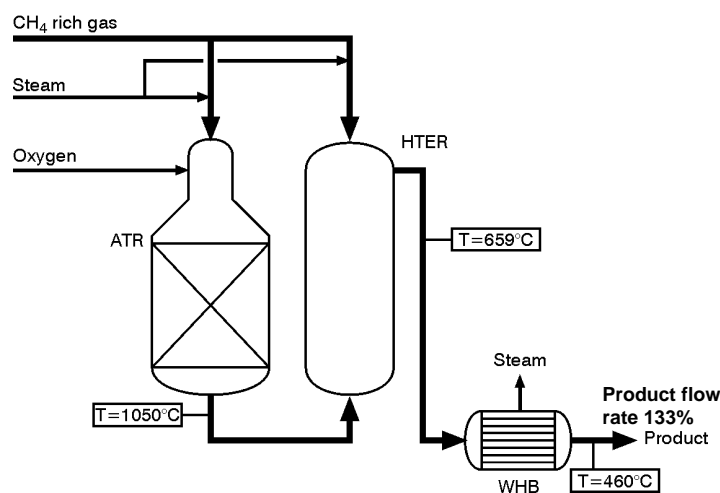

**Figure 8.** Layout of reforming section revamped with HTER

During the test-run, it was shown that the predicted capacity increase and conversion of the revamped unit was reached – in fact, there was some additional capacity in the unit compared to the expected figures of a 33% capacity increase. Likewise, the pressure drops were found to be stable and well within the anticipated values.

Four years of operating experience with the revamped unit has proven the viability of the HTER revamp concept. The operational benefit was achieved as anticipated, and Sasol and Topsøe are jointly in the process of studying how future capacity expansions can be made with this proven technology.

## 6 Use of the HTER technology in ammonia plants

In the reference plant with Sasol Synfuels, the HTER is placed downstream of an ATR, but the HTER is equally well suited to be located after a secondary reformer or even after a stand-alone tubular reformer. The technology is thus generally interesting in many business areas such as hydrogen production, methanol production, GTL/CTL and ammonia production. In this section, we shall be looking specifically into the HTER option for ammonia plant revamps, as illustrated in Figure 9 and Figure 10.

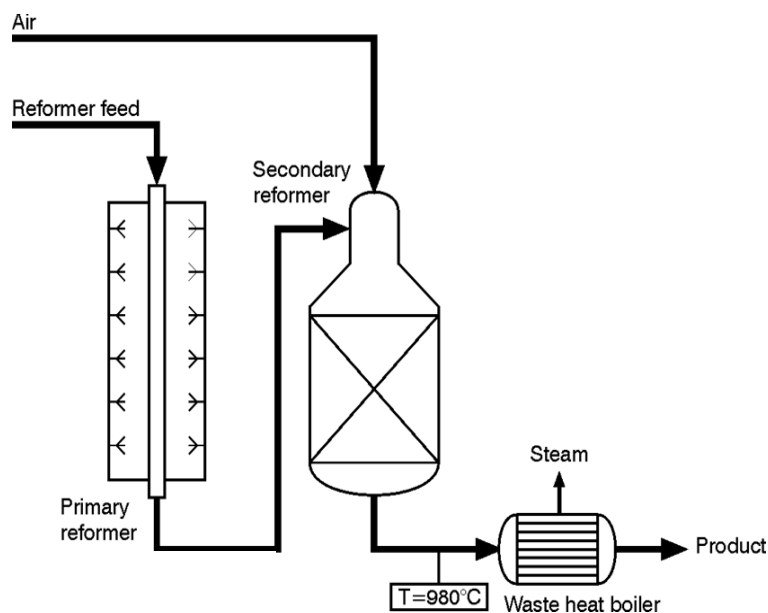

**Figure 9.** A traditional NH<sub>3</sub> plant reforming section

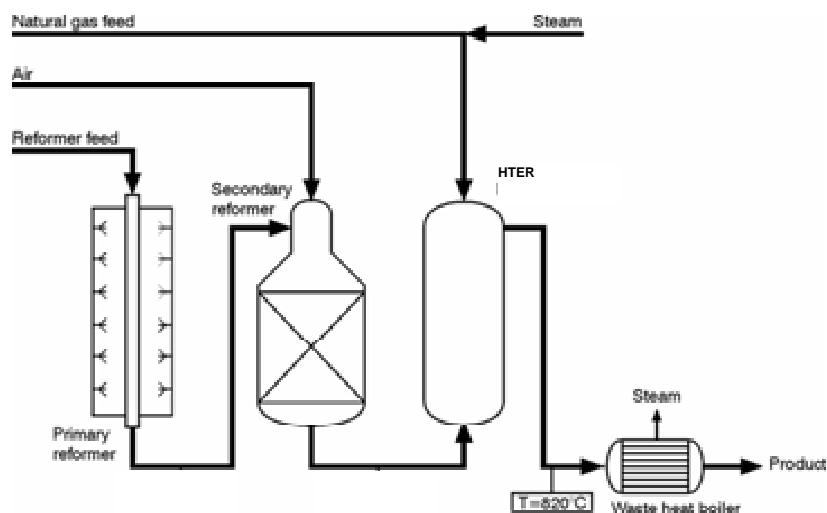

Figure 10. NH<sub>3</sub> plant reforming section with HTER

The parallel option can be executed in two ways: either the effluent from the secondary reformer (or ATR) is mixed with the reformed gas coming out of the HTER catalyst bed before cooling of the combined product gas, or the two streams are cooled separately and mixed at the exit. Both ways have their advantages, and the selection of option depends on the circumstances. For the revamp case at Sasol Synfuels, the first option was chosen. In other cases where a low CH<sub>4</sub> leakage is crucial such as in synthesis gas production for ammonia, the second option is the most attractive.

The HTER design can be made to accommodate both the above options and otherwise be optimised to suit the process requirements in the best possible way. The main features of the HTER will in all cases be the same as those demonstrated industrially at the Sasol Synfuels Gas Reforming Plant. The HTER suited for an ammonia plant will be made up of a number of double tubes that are furnished with a bayonet return tube. The heat transfer is laid out in such a way that only a very limited surface area will be subjected to metal dusting conditions, and consequently, the use of special materials can be minimised.

To illustrate a revamp situation for an ammonia plant, a comparison between a base case and the revamp case is made in the below table. As can be seen, a 25% increase in reforming capacity and equivalent ammonia production can be achieved by introduction of the HTER. It is noted that this capacity increase could equally well be translated into an unchanged capacity and a correspondingly smaller load on the primary reformer.

	<b>Base case</b>	<b>HTER revamp case</b>	<b>Change</b>
Dry product flow, kNm <sup>3</sup> /hr	190	237	+25%
Equivalent NH <sub>3</sub> production, MTPD	1500	1875	+25%
CH <sub>4</sub> leakage	0.44	0.38	
Steam production in WHB	100%	90%	

**Table 1.** Key figures for the base case and the same ammonia plant revamped with an HTER

The steam production in the synthesis gas WHB is lowered by 10% only, but it should be emphasised that the total steam production in the plant (including the ammonia loop) is essentially unchanged compared to the base case. This means that it will not be necessary to upgrade the steam system in the plant, which will save both time and investment cost for the revamp. It can also be noted that the methane slip is kept around the original level in order to keep the inert level in the loop unchanged.

The above case clearly demonstrates that the HTER technology is attractive as a revamp option for an ammonia plant. It is most advantageous when cheap fuel is available to generate the “missing” steam production required for the revamped capacity. This could for example be a situation where cheap coal is available to produce steam.

In the revamp option, the mechanical layout needs special consideration based on the actual available space in the plant. Often it is possible to locate the HTER next to the secondary reformer and re-route the exit transfer line to the bottom of the HTER. The combined exit gas from the HTER is led back to the existing WHB, preferably without moving any equipment in the front-end. It should be noted that there is no need for any special start-up system, because the HTER is easily heated up and put on-stream together with the primary and secondary reformer. Please see figure 11 which illustrates one way to install the HTER after the secondary reformer.

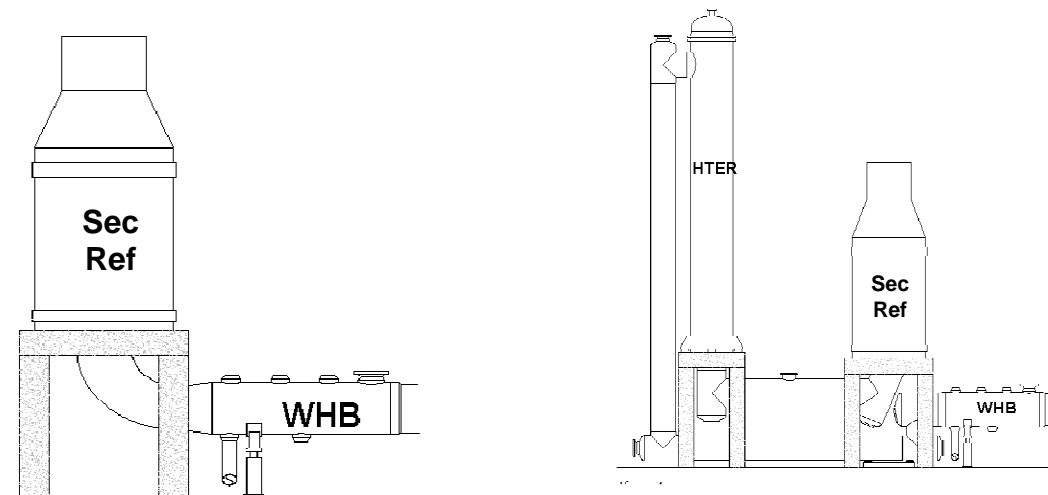

Figure 11. Layout of ammonia plant reforming section before and after revamp with HTER

## 7 New large-scale ammonia plants

The developments mentioned above are also very interesting for the design of large scale ammonia plants, and can be used to keep the size of the most critical part of the equipment at reasonable sizes. As such both the prereformer and/or the HTER-p are used to reduce the size of the primary reformer.

### 7.1 Conventional scheme – 4000 MTPD

The "conventional" scheme as shown in Figure 12 above is well referenced, and can easily be scaled up compared to the capacities being considered today. It is a simple scale up, where optimised operating conditions, for the reforming section and the ammonia synthesis loop in particular, are defined in order to keep the equipment sizes at a minimum. In this aspect the prereformer and the HTER are key elements in keeping the reformer size as low as possible, and to reduce the steam export in stand alone ammonia plants.

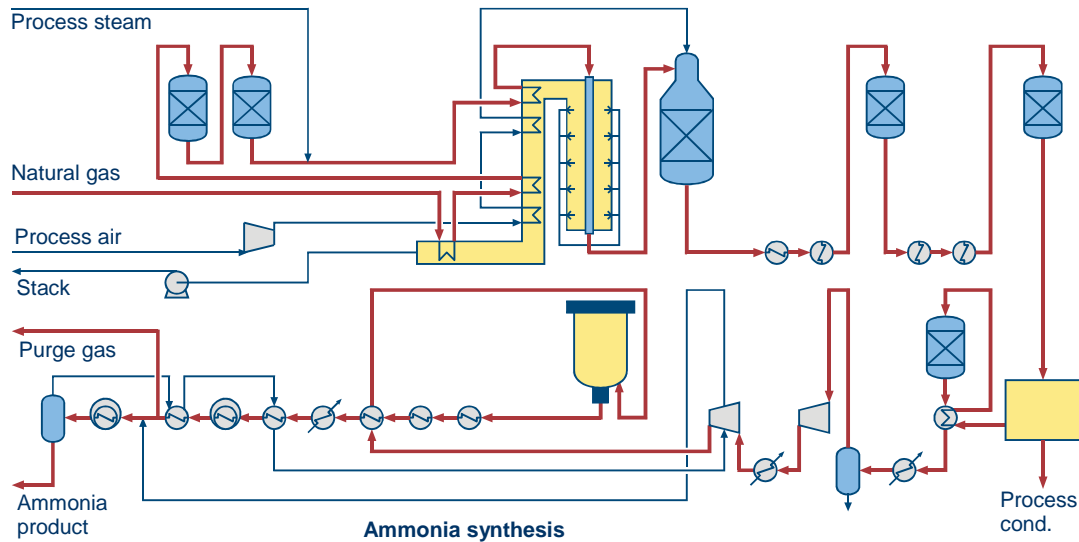

**Figure 12.** Conventional scheme for 4000 MTPD plant

Looking at the investment cost, the reformer cost goes up more or less proportionally with the number of tubes, and since the reformer cost is a significant part of the overall plant cost, it is important to keep the reformer size small, and thereby minimise the plant cost.

From an energy point of view, there is no doubt that this scheme is very energy efficient, and gives the lowest specific energy consumption figures of all currently studied schemes considered for large scale plants.

Our investigations show that up to a capacity of approx. 4000 MTPD the “conventional” scheme is the preferred scheme.

**7.2 ATR Scheme – 5000 MTPD**

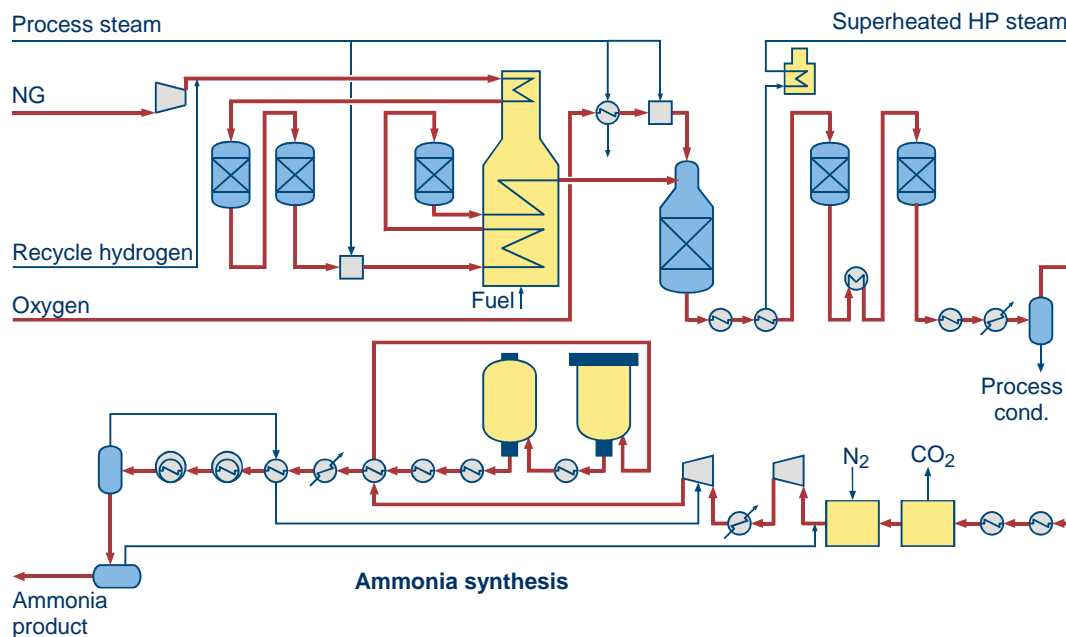

**Figure 13.** ATR scheme for 5000 MTPD plant

When very high ammonia plant capacity is desired, the technology used for the reforming section may change to an autothermal reformer based reforming unit, to utilise the benefit of the ATR for very large plants as a result of economy of scale considerations. The ATR scheme is illustrated in Figure 13.

The ATR is fired with oxygen produced in a dedicated air separation unit (ASU), and a hydrogen-rich synthesis gas is produced. This synthesis gas is passing through the two shift reactors before the CO<sub>2</sub> is removed. Nitrogen for the ammonia synthesis is produced in the ASU and added in a nitrogen wash unit (NWU) located just upstream of the synthesis compressor. In this way the gas flow through the front-end is kept at a minimum. The steam to carbon ratio can in principle be very low in the ATR, often below 1 in synthesis gas plants, but in ammonia plants, due to the shift reaction and heat input requirement for the CO<sub>2</sub> section, the steam to carbon ratio is kept at a relative high level – around 2.2 – 2.3 depending upon actual gas conditions.

After the NWU the synthesis gas contains only hydrogen and nitrogen in the desired ratio, and the ammonia synthesis can be operated under inert-free conditions. This results in minimum flow in the ammonia synthesis loop, and the converter size is minimised as well due to the very reactive synthesis gas.

### 7.3 Autothermal reformer (ATR)

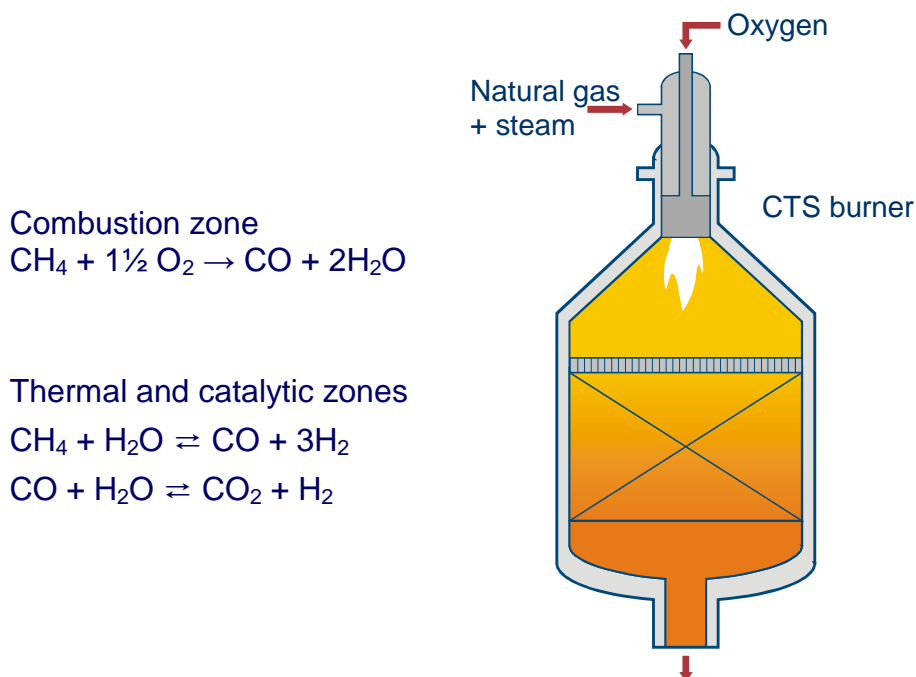

Figure 14. Autothermal reformer

Figure 14 shows the ATR, where partial combustion of the hydrocarbon feed with oxygen is followed by hydrocarbon conversion due to the steam reforming reactions in the catalyst bed. The exit temperature is typically above 1000°C, and this ensures low CH<sub>4</sub> leakage even at high pressure.

Contrary to the primary reformer (where the cost increases almost proportionally with the number of tubes), the ATR is scaled up by increasing the size of the adiabatic reactor. In such a case there is a benefit of the economy of scale, and the cost will not increase proportionally to the capacity increase.

Also for the air separation unit (ASU), supplying oxygen for the ATR and nitrogen for the NWU, there is a benefit of economy of scale. Especially for capacities above 4000 MTPD the ATR along with an ASU becomes attractive from investment point of view compared to the "conventional" scheme previously described.

Energy consumption is slightly higher for the ATR scheme compared to the "conventional" scheme, mainly due to the energy consumption of the ASU. However, in cases where the gas is cheap, the energy consumption is normally considered of minor

importance. For further details regarding the comparison of the “conventional” scheme with the ATR scheme, please see Table 2 below.

In general, the ATR is applicable for generating synthesis gas in large quantities for one or more downstream synthesis units, and has a number of advantages:

- ATR is used in many different industries
  - Gas-to-liquids (GTL)
  - methanol
  - ammonia
  - synthesis gas generation
- Simple unit operation
- Well-proven technology in Topsøe ammonia plants since 1958
- Easy to scale up to very large capacities

Process concept	Steam reforming	ATR
Capacity, MTPD	4,000	5,000
Steam reforming	Yes	No
Secondary reforming	Yes	No
ATR	No	Yes
Final purification	Methanation	N <sub>2</sub> wash
Synthesis loop configuration	S-350 with inert	S-350 inert-free
Net energy consumption, Gcal/MT NH <sub>3</sub>	Base	+ 6%
Rel. specific investment (per MT NH <sub>3</sub> capacity)	Base	- 14%

**Table 2.** Comparison of “conventional” and ATR scheme

## 8 Conclusions

The new features described in this paper are applicable for revamps jobs as well as for new plants.

The ATR is well known from other industries and can be used with benefit (due to economy of scale) for very large capacities around 5000 MTPD of ammonia.

The novel revamp feature, the Haldor Topsøe Exchange Reformer (HTER-p), is an attractive option for increasing the capacity of the reforming section in an ammonia plant, and in particular for very large stand alone ammonia plants this is an excellent feature in order to reduce the steam export.

## References

- (1) Nielsen S. E. "Recent Experience of Debottlenecking and Energy Conservation in Indian NH<sub>3</sub> Plants", FAI Seminar, New Delhi, November 28-30, 2006
- (2) Nielsen S.E., Christensen P. V., "How to Bring Existing Ammonia Plants Up-to-date", Ammonia Plant Safety & Related Facilities proceedings, Vol. 45, p. 168-176, AIChE, New York (2004)
- (3) Thomsen S. G., Han P., Loock S., Ernst W. " The First Industrial Experience with the Haldor Topsøe Exchange Reformer ", Ammonia Plant Safety & Related Facilities proceedings, Vol. 47, p. 259-266, AIChE, New York (2006)