

WSA for cleaning of acid gas from gasifier

Sokolovská Uhelná a.s., Vresova, Czech Republic

RESEARCH | TECHNOLOGY | CATALYSTS

Background

For many years Sokolovská Uhelná a.s. produced town gas by means of gasification of lignite. The acid gas, coming from the Rectisol wash installed after the gasifier, contained a considerable amount of H₂S, COS and hydrocarbons in addition to CO₂. These gases were previously vented to the atmosphere, but now the acid gas needed purification in order not to affect the environment with SO₂ emission. This requirement led to the implementation of a Topsøe WSA plant in 1993.

Considerations

Not only could the WSA process meet the demands of SO₂ removal, the process could also accept a wide range of feed gas compositions and was capable of treating the complex acid gas coming from the gasifier, which would have been difficult or even impossible to handle with other processes. These features made the WSA process a perfect choice for the client.

The Topsøe approach

The WSA process is a wet gas catalytic process, which recovers sulphur from hydrogen sulphide and other sulphur compounds as concentrated sulphuric acid of commercial grade.

The WSA plant provides a high sulphur recovery, and the heat recovered from the high content of hydrocarbons present in the strip gas causes a substantial steam production. The heat recovery rate is high and the cooling water consumption low, resulting in superior cost performance of the WSA process.

Some years after the implementation of the WSA plant, the introduction of natural gas made the gasifier redundant. However, due to the advantageous heat economy of the WSA plant, the client decided to convert the overall plant to a power plant and expand its capacity. The WSA plant now produces steam, and the gasifier supplies clean coal gas to a gas turbine for electricity production. This would not have been possible with other types of desulphurisation plants.



WWW.TOPSOE.COM

In 2003 the WSA plant was revamped to comply with increased capacity demands and more stringent emission control requirements.

The overall scope of Topsøe supply for this WSA plant was basic and detailed engineering, catalysts, proprietary equipment and supervision. The project was carried out in close collaboration with the client and their local engineering company acting as the main contractor.

Summary

The plant has been in operation since 1993. The client's requirements to both emission limits and high steam production have been met without problems throughout the operating period.

Why choose WSA for your gasifier?

- flexibility in feed composition: high CO_2 , low H_2S and high and varying hydrocarbon content can be accepted
- more than 99% of the sulphur is recovered as concentrated sulphuric acid of commercial grade
- attractive operating economy
- simple layout, simple operation
- small footprint
- Topsøe offers single source responsibility: design, engineering, catalyst, hardware and service – all in one hand

References

Currently (2008), nine WSA plants are in operation or under construction for gasifiers, and in total more than 70 WSA plants have been contracted for various applications.

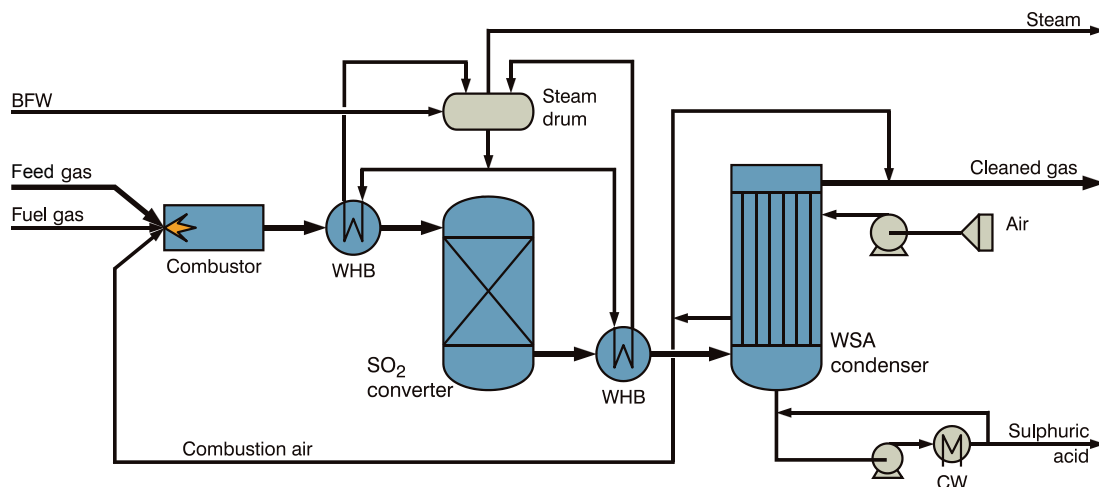

Key data

Feed gas flow:	14,000 Nm ³ /h
Composition [vol %]:	5.8% H ₂ S, 1.2% COS, 9.7% HC, 77.4% CO ₂
SO _x concentration [vol %]:	1.58%
H ₂ SO ₄ production:	106 MTPD
Steam production:	53 ton/h
Cooling water consumption:	8 m ³ /ton acid (ΔT = 10°C)
Fuel consumption:	1,000 Nm ³ /h (LHV = 2,821 kcal/Nm ³)
Power consumption:	470 kWh/h