

Hydrotreater revamp case story: Making the most of what you have

RESEARCH | TECHNOLOGY | CATALYSTS



Introduction

Bharat Petroleum (BPCL) was faced with a serious challenge when they needed to revamp their diesel hydrotreating unit (DHDS) in Mahul. This unit, originally from 1999, operated with 25-30% cracked feed at low pressure (41 barg). The new conditions required an increase in load by 43% and a reduction in sulphur by 97%.

The paper presents how Topsøe has enabled BPCL to achieve their overall goal “Making the most of what you have”, by implementing specially tailored revamp layouts. This particular example requires extensive knowledge of system behaviour, catalyst and reaction patterns.

The goals and challenges

The goals were the following:

- Throughput increase from 4200 MTPD to 6000 MTPD
- Reduce sulphur in diesel product from 350 wppm to 10 wppm
- Catalyst cycle length minimum 3 years
- Installation had to be done in only 40 days during turn-around

The challenges were the following:

- Low pressure, 41 barg
- Large variety in feed composition
- High radial temperature spread in existing reactor beds
- Congested plot space
- Vibrations in charge heater
- Power restrictions for recycle gas compressor and charge pump
- Various hydraulic limitations
- Low capital expenditure thus maximum reuse of existing equipment

BPCL had made a precise identification of the unit’s hydraulic bottlenecks in advance. An 8 week study phase was arranged for quantifying all bottlenecks and analysing the various possible layouts.

It was clear from the beginning that a simple revamp with just extra reactor capacity would not solve the associated problems. Topsøe took an innovative approach in handling all the challenges and decided on a special design in close cooperation with BPCL. The design minimised Capex and Opex and resulted in the most favourable Net Present Value (NPV). The NPV evaluation method was used by BPCL to evaluate which design was the most favourable over time.

The feedstock

The primary feed was Feed 1 shown in Table 1, whereas Feed 2 was an alternate feed which would be run occasionally. Product specifications needed to be met on both feeds.

| Property | Feed 1 | Feed 2 |
|-----------------------|--------|--------|
| Flow, MTPD | 6,000 | 5,850 |
| Specific gravity | 0.865 | 0.844 |
| Sulphur, wt% | 1.5 | 0.4 |
| Nitrogen, wppm | 200 | 170 |
| Bromine number | 7 | 0.7 |
| Cetane index, D-976 | 47.7 | 53.5 |
| Aromatics, wt% | | |
| Mono aromatics | 20 | 16 |
| Di aromatics | 13 | 10 |
| Tri aromatics | 2.6 | 1.7 |
| Distillation, D86, °C | | |
| IBP | 168 | 185 |
| 10% | 241 | 242 |
| 30% | 272 | 270 |
| 50% | 295 | 289 |
| 70% | 320 | 309 |
| 90% | 363 | 343 |
| FBP | 456 | 385 |

Table 1: Feedstock

Primary product specification

The main product specifications are given in Table 2.

| Product quality | Lab method | Value |
|--|-------------|-------|
| Sulphur content, wppm | ASTM D-5453 | 10-45 |
| Cetane number improvement (Δ CN) | ASTM D-613 | + 5 |

Table 2: Product specification

The variation in sulphur is driven by a required maximum 45 wppm S specification and a preferred 10 wppm S specification for some of the time.

Primary operating conditions

| Parameter | Value |
|---|-------|
| Reactor pressure, bar g | 41 |
| Treat gas/oil ratio, Nm ³ /m ³ | 300 |
| H ₂ consumption average, Nm ³ /m ³ | 61 |

Table 3: Operation conditions

Primary revamp recommendations

The study phase resulted in the following primary recommendations by Topsøe:

- New high-activity catalyst from Topsøe
- New reactor internals from Topsøe
- Add one extra reactor to reach the required catalyst volume
- Place the new reactor in parallel service to the existing reactor
- Heat the second reactor train by reactor effluent from the first reactor
- Install vertical helix exchangers in second reactor train to save plot space
- No replacement of existing equipment

Thus, the concept was to reuse the existing unit and then build in a parallel reactor train into a limited plot space, and at the same time reduce the mass load on the fired charge heater (Figure 1).

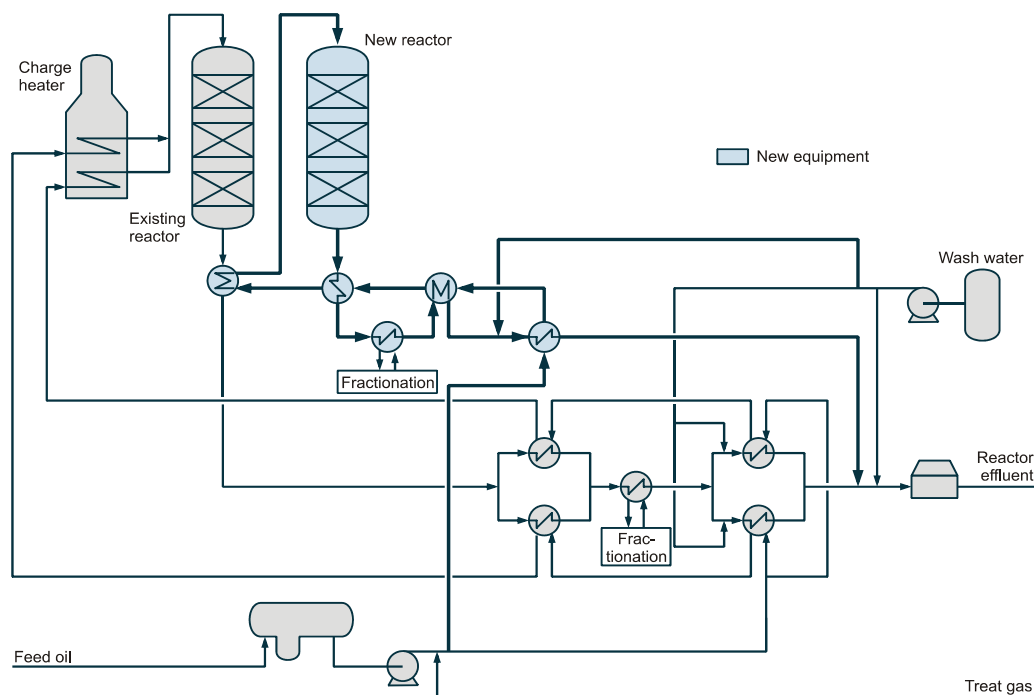

Figure 1. Reactor section heat integration

The reasoning behind these recommendations is explained in the following pages.

Implemented recommendations

All of the above listed recommendations were well-received by BPCL and accepted during the design phase.

Plot restriction is a major problem in many revamps, and equipment selection is an important parameter in order to minimise the required plot space.

As a consequence of the suggested vertical heat exchangers, the unit had to be built upwards. The original plot space did not allow for any other major additions than the new reactor. By choosing vertical heat exchangers, it was possible to build the unit upwards, thereby solving the plot problem.

Various types of heat exchangers had been considered in order to handle the limited plot space. In the end, BPCL decided to make place for a platform where shell tube heat exchangers could be placed. This was done by removing a soda ash vessel, making it possible for BPCL to use ordinary well known shell tube heat exchangers for the new preheat train, but at the expense of plot space.

Catalyst selection

A very important contribution to the success in this revamp is the catalyst selection. Topsøe's BRIM™ series of catalysts, which is developed and manufactured in-house, has an impressive record for use in diesel and kerosene hydrotreaters.

The unit required a catalyst with maximum volume activity to bring down the reactor cost. The BPCL operating conditions as well as feed specifications favour a CoMo type catalyst over a NiMo type, as the primary constraint is to reach the sulphur specification of the 10 ppm sulphur at around 40 bar pressure. Since the feed had up to 30% cracked material, using a CoMo catalyst has the further benefit that the hydrogen consumption is significantly reduced compared to using a NiMo catalyst. This meant that it was not necessary to revamp the make-up gas compressors.

TK-576 BRIM™ was installed in the unit. Since then, a new generation of BRIM™ catalysts has been commercialised. By improving dispersion, the number of active sites for a given metal loading is increased. This results in a higher activity for the catalyst, or alternatively, provides the possibility of maintaining the same activity with a lower metals loading on the catalyst. As a result we can offer our clients a variety of products with different activity levels at different fill cost.

Table 4 gives an overview of these new generation BRIM™ catalysts and the relative activities within a group of comparable catalysts.

| Application | Catalyst | Relative activity | Cost |
|----------------|--------------|-------------------|-----------------------|
| ULSD (CoMo) | TK-568 BRIM™ | Base 1 | lowest filling cost |
| | TK-570 BRIM™ | Base 1 + 15% | low filling cost |
| | TK-578 BRIM™ | Base 1 + 40% | standard filling cost |

Table 4: New generation ULSD CoMo catalysts

These catalysts can make ULSD to less than 7 wppm sulphur in units with as low as 20 bar pressure and they have unmatched stability. Even if the feed blend contains cracked feeds from thermal units or cracking units they maintain their stability.

It is well known that the use of NiMo catalysts typically results in a higher cetane number (CN) increase from feed to product than CoMo types. However, CoMo catalysts are able to gain a CN increase of 5 or higher at low pressure if the feed is right. CN was not the primary bottleneck in this revamp case.

Several diesel units operating at these low pressures have been successfully revamped by Topsøe with CoMo catalyst [1]. It is often extremely financially attractive for the refiner to do this type of revamp rather than to replace it with a higher pressure unit.

Reactor internals

In order to fully utilise all of the catalyst, it is necessary that the gas and liquid distribution in the reactors is near perfect. This is achieved by having the latest generation of Topsøe reactor internals in both reactors, new and old.

The old reactor internals had a poor performance with high radial temperature spread (>15°C) in the bottom of the reactor beds. It is an indication of a poor distribution between liquid and gas in the cross section which prevents effective usage of the catalyst volume. The new reactor needed new internals combined with an arrangement of flex thermocouples and consequently it was decided that the old reactor would get the same arrangement for the revamp.

The Topsøe internals are preferably installed together with an arrangement of flex thermocouples in order to enhance safety in the unit and for the operators to better monitor any changes over time in the reactor.

The newest mechanical improvements of Topsøe reactor internals facilitate fast access through the internals. Passage through each piece of internal including the dismantling time can be done in less than 5 minutes. This arrangement speeds up a re-loading of the catalyst significantly. With older generation trays the same work could take 3-4 hours.

Furthermore, a new Topsøe design makes it extremely fast to install new internals. It is possible to achieve installation time savings of approximately 50-75% of the time required for the previous generation, which makes new installations in old reactors simpler and less costly.

Topsøe internals can be installed in old reactors even if support rings are missing. The mechanical design can handle special solutions. It gives the refiner the option to upgrade old reactors to ULSD service if the vessel material is in order, mechanically and process wise.

Revamp process layout

The existing unit had simple 2 train shell tube heat exchangers in a layout with amine absorber and without hot separator. The stripping section used steam stripping. Salt driers were used for drying the diesel product.

The result of the revamp was a new unique fired heater and reactor configuration (Figure 2).

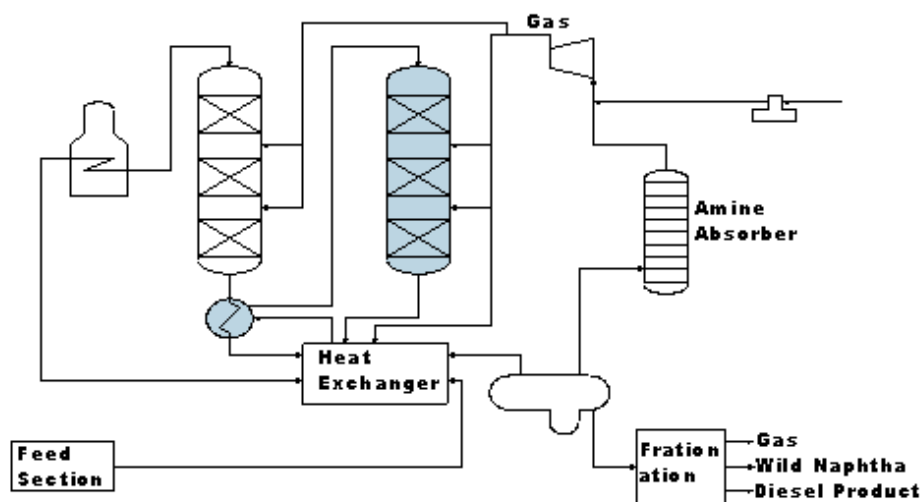

Figure 2. Revamp process block layout

Major modifications

An important economical aspect of the revamp was that no equipment would be replaced. Therefore, it was necessary to make significant layout changes in the layout of the reactor section.

One of the key revamp issues was how to handle a vibrating fired heater under new conditions with 43% higher throughput. These vibrations were in the process piping and coils. Vibrations had been observed already at 4500 MTPD (+10% load) through the coils when performing a capacity test run.

It turned out that a direct equipment revamp of the heater to handle the required 43% higher load would be very expensive. Therefore, it was decided to follow the difficult step of having a separate heat source for a new parallel reactor instead of the fired heater (Figure 3).

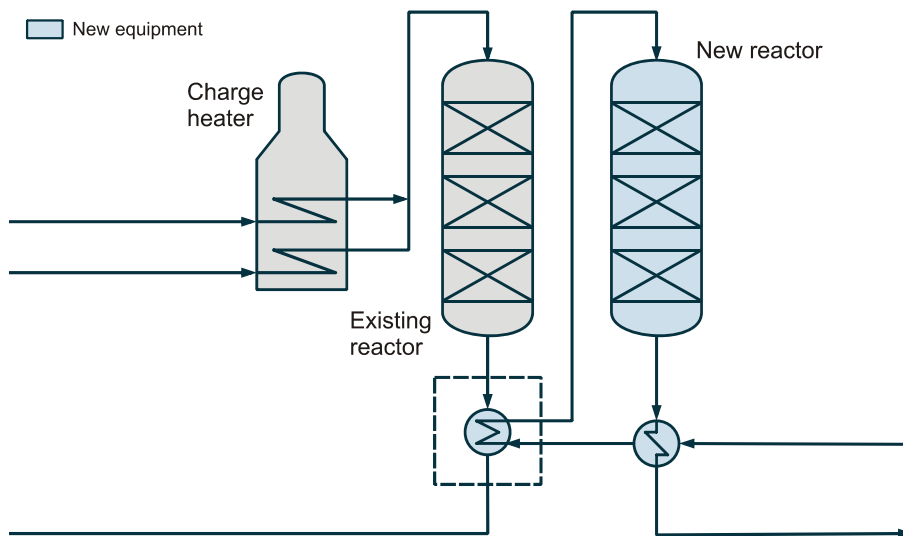

Figure 3. New reactor preheat arrangement

A parallel layout would solve the pressure drop problem in the reactor loop and also limit the mass flow to the charge heater which was needed to prevent vibrations. A serial layout would not solve these problems without costly modifications of the charge heater and the recycle gas compressor and a parallel layout was chosen.

The biggest challenge was to set up the heat integration correctly in order to handle all feed cases at normal conditions as well as to be able to start up the second reactor train with enough heat. In fact, the easy low sulphur feeds were the difficult ones to design for with regard to the heat integration because the exotherms in the reactors were low.

The inlet to the new reactor required a feed/effluent heat exchanger using effluent from the first reactor. This arrangement is delicate because it could complicate start-up significantly and the two reactors might have to operate with uneven temperatures if the design was not correct. It required rigorous pinch analysis of the heat exchanger system to do the design correctly.

The new design had to handle all operational possibilities ranging from start-up case with catalyst sulphiding to uneven deactivation of catalyst in the two reactors. It complicated matters that an alternate feed with low exotherm was part of the design criteria. This part required extensive knowledge of catalyst and system behaviour.

Minor modifications

After a thorough review of the unit it turned out that various minor changes had to be made. Most of these were addressed already in the proposal phase as points which might require change of some kind.

The columns both required new trays to accommodate the higher hydraulic load.

It was necessary to insert a new type of coalescing element in the cold separator to improve the separation efficiency. It prevented an extension of the vessel which would be problematic in connection with the limited plot space.

Various pumps required an extra pump in parallel to handle the new conditions. This meant that two pumps would be in operation with one as spare.

Various air coolers needed modification in the form of extra bays. This also affected the plot space on the pipe racks. The alternative solution of putting in water coolers was not possible due to refinery constraints.

Various parts of the unit required a parallel line of heat exchangers to cope with the higher capacity.

Apart from one pump replacement, the new design managed to keep the existing equipment intact. All other original equipment pieces are in use today.

Installation time

In order not to extend the overall time for the planned turn-around, it was a requirement from BPCL that the shutdown time of the DHDS unit did not exceed a maximum of 40 days. It required a thorough analysis already in the basic design of what type of site work could be done during normal operation and what kind of work that required a complete shutdown.

Already ahead of the shutdown, it was also clear that in order to avoid any delays, a good line of communication had to be established, and BPCL's resource needs had to be clearly identified. This was done by several meetings ahead of the shutdown together with the project team from BPCL. One conclusion from these meetings was that the shutdown schedule was extremely tight and that it was necessary that Topsøe made technical personnel available to BPCL on short notice for various assignments.

Engineers from Topsøe participated in mechanical installation of reactor internals, catalyst loading, piping and equipment inspection. With this method of work it was possible to achieve the installation of the equipment within the scheduled time.

The results of the site activities also paid off as there has been no need for any re-designs after start-up as any potential installation errors were caught before the start-up and could be rectified.

Performance after start-up

The combined catalyst and reactor internals performance is shown in Figure 4. The normalised temperature is the measured weight average bed temperature normalised to a given set of conditions and product sulphur level.

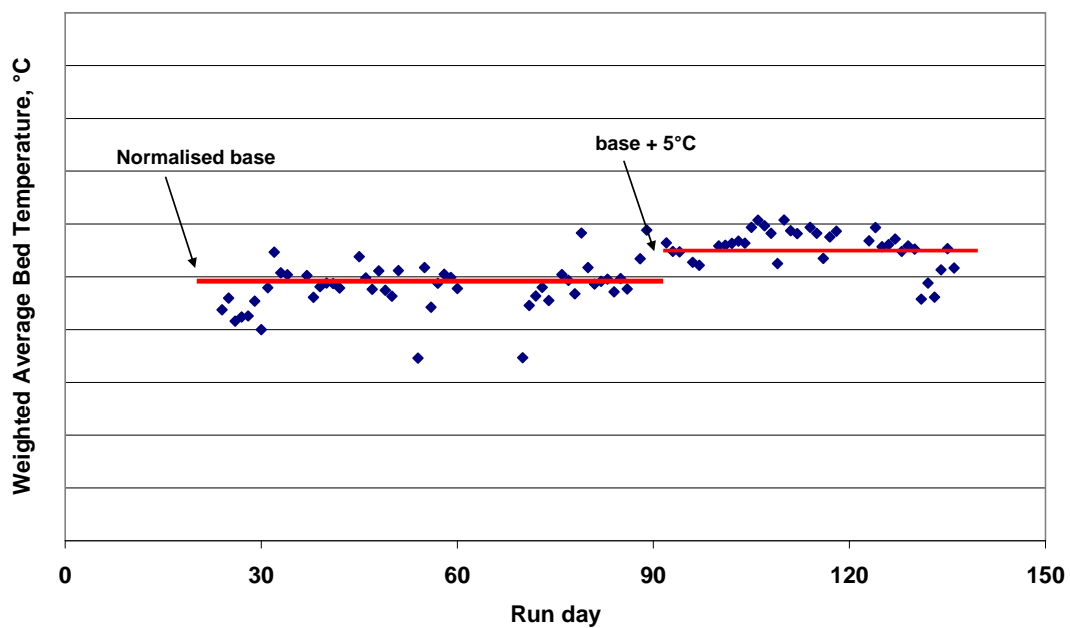

Figure 4. Reactor temperature after revamp

Figure 4 shows a stable pattern where the operating reactor temperature is almost constant. A change to a more refractory feed after 3 months changed the temperature to a higher but stable level. An extrapolation of the temperature level will result in a cycle length above the required minimum of 3 years.

The reactor internals are evaluated from the radial temperature spread in the reactor beds. The ideal spread value is zero. The performance is shown in Table 5.

| Before revamp | After revamp |
|---------------|--------------|
| > 15°C | < 5°C |

Table 5: Reactor radial temperatures

The equipment hydraulic bottlenecks have all been eliminated. The unit has been operating at the new design feed rate for most of the run. See Figure 5.

The payback time based from initial start-up is estimated to be 1-1½ year if the unit operates the design feed at the design rate.

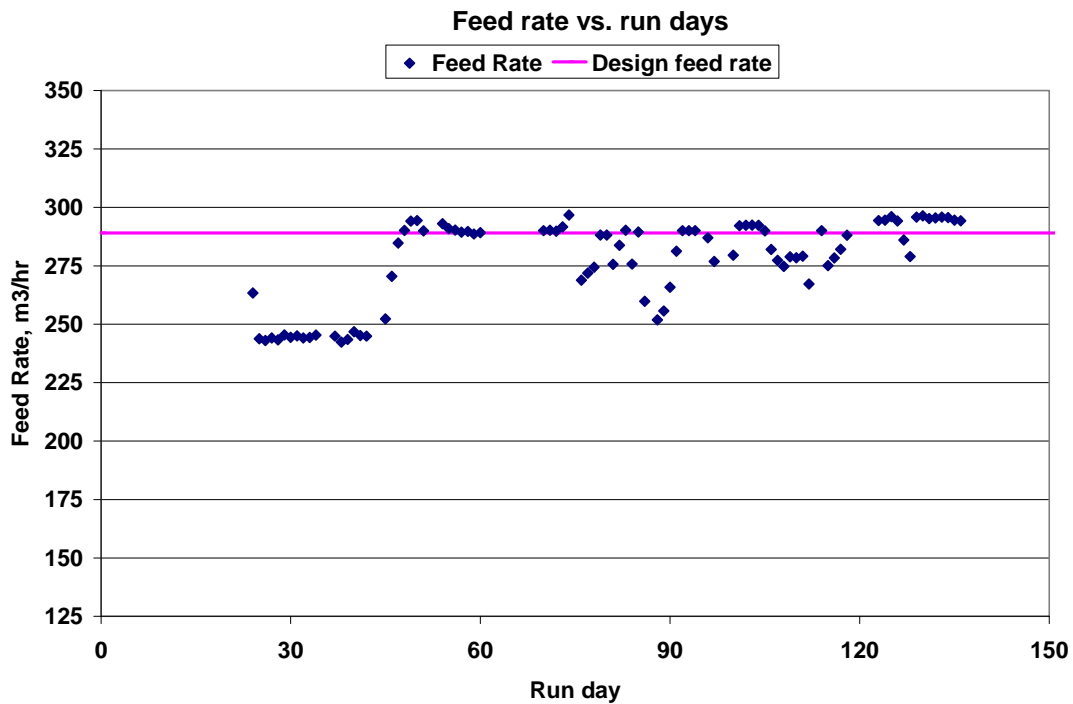

Figure 5. Feed rate after revamp

Summary of results

The goals for the design were all achieved:

- The 41 barg unit with up to 30% cracked feed makes 5-45 wppm S
- Low deactivation rate; more than 3 years expected catalyst cycle length

The unit is operating well in the middle of its first cycle after the revamp:

- Installation time achieved within 40 days
- All guarantees accomplished

The unit was started up and passed a guarantee test run 2 months later.

All the challenges were overcome and the following are in particular worth highlighting:

- The hydraulic capacity is at least 6000 MTPD
- Radial temperatures in reactor improved from greater than 15°C to less than 5°C
- Almost complete reuse of existing equipment
- Payback time estimated to be 1-1½ year

Topsøe experience

Topsøe is the leading licensor in the open market for diesel/kerosene hydrotreating and has an innovative approach to the challenges of a complex revamp. Topsøe has performed more than 30 revamps in the last 10 years.

Since 2002 Topsøe has produced catalysts using the proprietary BRIM™ preparation technology, which today widely is considered to be a leading technology. The BRIM™ series of catalysts has an impressive track record and are at present operating in more than 300 hydrotreaters in services ranging from naphtha to heavy VGO.

Five years after the launch of the first BRIM™ catalysts, a new second generation of BRIM™ catalysts were commercialised. Seven new BRIM™ catalysts have been released since the end of 2008, and the number of references has exceeded 100 after less than two years.

Topsøe has state-of-the-art reactor internals, and we have an ongoing programme for making improvements both from a process and mechanical perspective.

Topsøe combines our in-depth knowledge of catalysts, technology and kinetics to provide unique and optimised solutions for our customers, as exemplified by the BPCL revamp.

Author

Torkil Hansen is General Manager in the refinery process department in Haldor Topsøe's Technology Division. He graduated with a MSc degree in Chemical Engineering from the Danish Technical University of Denmark and has worked 13 years in hydroprocessing for Haldor Topsøe.

E-mail: tih@topsoe.dk

- [1] Systematic Approach for the Revamp of a Low Pressure Hydrotreater to Produce 10 ppm 'Sulphur Free' Diesel at BP Coryton Refinery