

Impact of biomass co-combustion on SCR DeNO_x operation

by:

*Hans Jensen-Holm
Joakim Reimer Thøgersen
Peter Lindenhoff*

Haldor Topsøe A/S

Presented at Power-Gen Europe, Germany, 2009
Best paper award within the conference track
'Coal, Nuclear & Biomass Generation'



Abstract

With increasing requirements for reductions of CO₂ emissions from the power-generating industry, there is a considerable interest in the utilisation of biomass and municipal and industrial waste in power plant boilers. Combined with still tighter limits on emission of NO_x, the use of biomass fuel represents a challenge to the designers of Selective Catalytic Reduction (SCR) units since the useful life of the SCR catalyst can be significantly reduced.

The mechanisms responsible for the catalyst deactivation are discussed. Alkali-metal aerosols formed during combustion of biomaterial can at worst cause complete deactivation of the catalyst within a few thousand hours of operation. Other components as e.g. phosphorous can cause severe fouling of the catalyst surface.

The paper describes a number of SCRs implemented to meet these new challenges and includes experience from a variety of plants firing biomass in Europe and the USA. Results from installations in units firing 100% biomass as well as installations in units with co-combustion of biomass with coal and oil are presented.

These experiences demonstrate that choosing the right plant configuration and proper catalyst formulation, the negative effect can be limited. Up to 20 weight per cent biomass can be co-combusted with the coals without any noticeable impact on catalyst lifetime. The use of SCR on 100% biomass-fired boilers may be done as a tail-end installation to minimise the amount of poisoning species entering the SCR.

Contents

Introduction.....	4
SCR deactivation mechanisms	6
Alkali and alkaline-earth metals	6
Phosphorous	10
Arsenic	11
Examples of experience from biomass-fired boilers	11
DONG Energy, Avedøre Power Station, Denmark	11
DONG Energy, Studstrup Power Station, Denmark	13
Electrabel, Langerlo Power Station, Belgium	16
Vattenfall, Combined Heat and Power, Sweden.....	17
Sierra Power, California, USA.....	19
Vattenfall, Amager Power Station, Denmark	20
Conclusions	22
References	23

Introduction

An increased production of electricity from renewable energy sources is being promoted and biomass co-firing with coal in existing coal-fired power plants represents an option for combined renewable and fossil energy utilisation to reduce CO₂ emissions. Biomass is considered CO₂ neutral with respect to the greenhouse gas balance if the use of fossil fuel in harvesting and transporting the biomass is not considered. Direct co-firing, i.e. firing the coal and biomass in the same boiler, is the simplest and most widely applied technology for co-firing biomass.

Possible biomass sources comprise e.g.:

Wastes and residues

- Wood and bark: forest or tree trimmings, sawdust, demolition wood, crates
- Agricultural residues: straw, olive residue, coconut chips
- Animal wastes: Poultry litter, meat bone meal
- MSW, sewage sludge, paper waste

Peat

Agricultural energy crops: Switchgrass, miscanthus, poplar and willow, bamboo

Biomass and coal have fundamentally different fuel properties. Biomass (and low-rank coals) contains larger relative quantities of alkali and alkaline-earth elements (potassium, sodium, calcium, magnesium), phosphorous and chlorine than coal. As all the constituents of the biomass enter the boiler, several technical concerns arise. Higher fuel chlorine contents can lead to greater high-temperature corrosion in boilers. Accelerated fouling and slagging can occur when high potassium containing fuels are utilised.

Also for the operation of SCR systems there are technical challenges associated with co-combustion of biomass and coal in boilers designed for coal. The constituents of biomass have the potential to impair the SCR as the SCR catalysts are susceptible to 'poisoning' due to condensation of volatile inorganic species on the catalyst surface. Formation of sulphate- or phosphate-based deposits on the catalyst surface or reaction with the catalyst's active species can significantly reduce catalyst activity, resulting in shorter lifetime. Biomass in the form of wastes may also contribute elements such as arsenic.

Table 1 shows examples of 'poisonous' components in the ash of various fuels and the related SCR catalyst deactivation rates. Figure 1 shows the deactivation trend for various fuel types as activity relative to fresh-catalyst activity versus operating time. The activity curves have been calculated using a deactivation model developed by Haldor Topsøe that considers ash deposition rate, pore plugging development and chemical impact on active sites.

		Bituminous coal	PRB coal	Heavy fuel oil	Peat PC boiler	Wood CFB boiler
Ash	mg/Nm ³	15,000	6,000	100	6,000	1,500
Soluble potassium	wt %	0.15	0.5	-	0.3	5.2
Soluble sodium	wt %	0.12	1.5	1.5	0.2	0.7
Nickel	wt %	-	-	20	0.01	-
Vanadium	wt %	-	-	20	0.01	-
Phosphorous	wt %	0.1	0.8	-	1	15
Calcium	wt %	0.5	22	1.1	15	5
SCR catalyst deactivation						
% per 10,000 hours		12	20	5	60	46

(model simulation cf. Figure 1)

Table 1 Fly ash characteristics of various fuels

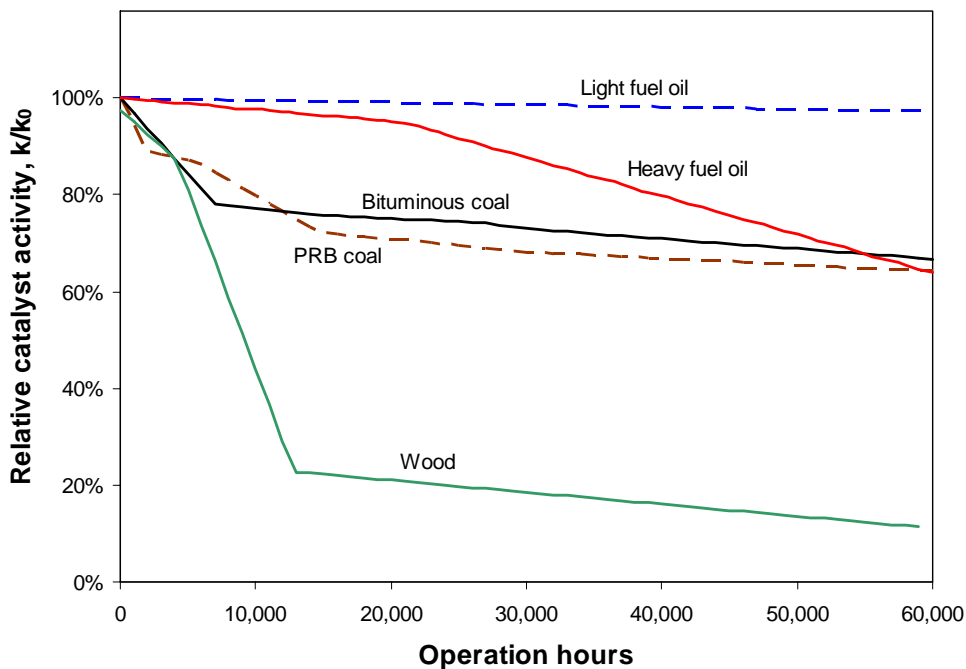

Figure 1 Expected deactivation of SCR catalyst for various fuel types

For biomass firing the SCR catalyst deactivation rate is significantly higher. Typical deactivation rates for installation in a high-dust position are shown in Table 2.

Fuel	Deactivation rate
100% straw	50% per 1,000 hours
Wood:	
- Pulverised-fuel boiler	60% per 10,000 hours
- CFB boiler	45% per 10,000 hours
- Grate-fired boiler	25% per 10,000 hours
Peat-fired boiler	30% per 10,000 hours
Coal-fired boiler	10% per 10,000 hours
Heavy fuel oil fired boiler	5% per 10,000 hours
Gas-fired boiler	2% per 10,000 hours

Table 2 Typical SCR catalyst deactivation rates. Actual deactivation rate depends on specific fuel composition

SCR deactivation mechanisms

Alkali and alkaline-earth metals

Alkali-metal aerosols formed during combustion of biomaterial are well known to be able to severely impact the performance of SCR catalysts. The sub-micron particles adhere to the surface of the catalyst and are readily transported to the active sites by surface diffusion. Spectroscopic studies suggest that the poisoning mechanism occurs via chemical bonding of the alkali metal to the crucial $-V-OH$ sites, the so-called Brønsted-acid sites which also adsorb and “activate” the ammonia, forming $-V-OM$ (M being K or Na) and thereby blocking the catalytic cycle (see Figure 2). Exposure to alkali-metal aerosols can at worst cause complete loss of activity of the catalyst within a few thousand hours of operation.

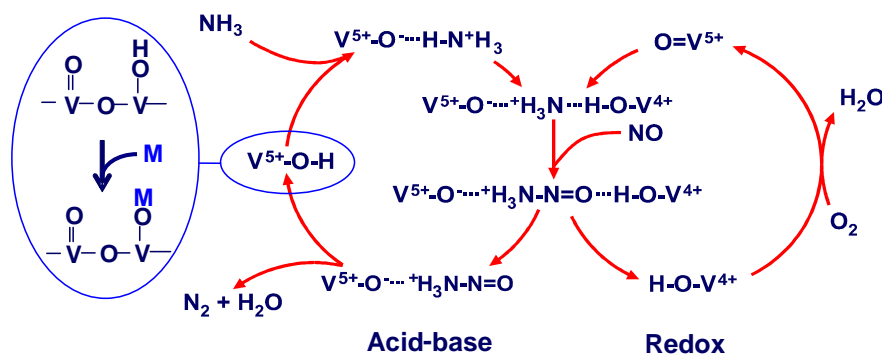

Figure 2 Basically, the SCR reaction involves both acid-base and redox catalytic functions. The reaction is initiated by the adsorption of ammonia on Brønsted acid sites ($V^{5+}-OH$), followed by “activation” of ammonia via reaction with redox sites ($V=O$). This “activated” form of ammonia then reacts with gaseous or weakly adsorbed NO , producing N_2 and H_2O while releasing $V^{4+}-OH$. To complete the catalytic cycle, the $V^{4+}-OH$ species is oxidised by either NO or O_2 to regenerate the original $V=O$ species (from [1])

Cf. Table 2, exposure to flue gas from straw combustion results in a very rapid catalyst deactivation. Studies have shown the flue gas to have a high mass concentration (up to more than 2 g/Nm³, depending on type of straw) of submicron particles of 0.15-0.30 μm size (number geometric mean diameter). The particles, which are mostly compact agglomerates, consist of almost pure potassium chloride and sulphate with minor amounts of sodium, phosphorous and calcium [2].

In a study by the CHEC group at the Technical University of Denmark in collaboration with Haldor Topsøe, full-length monolith catalyst samples were exposed to aerosols of pure potassium chloride and -sulphate in a bench-scale reactor shown in Figure 3 [3]. An aerosol of the salt was then generated by injecting the solution of the salt into the flue gas close to the burner where the temperature was 1000–1150°C. Activities of the catalysts were measured in situ at 350°C typically 2–3 times per day. The catalyst activities as a function of exposure time to the flue gas are shown in Figure 4.

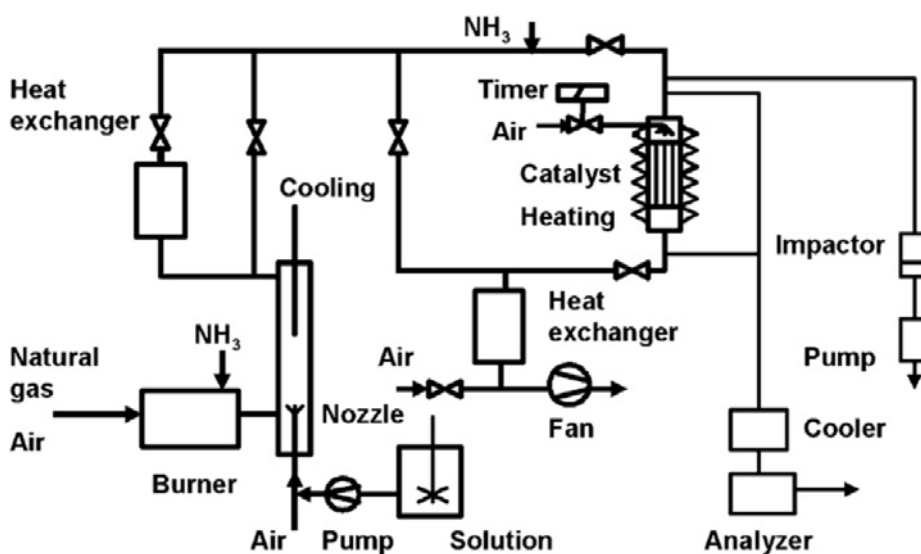

Figure 3 Experimental set-up for catalyst exposure tests (from [3])

Figure 4 (left) shows that after exposure to KCl aerosols at 350°C for 715 hours, the catalyst relative activity was about 69%, which corresponds to a deactivation of about 1.0% per day. There was also a fast decrease of the adsorption capacity for NH₃ on the catalyst. Then the system was cleaned and without addition of KCl the catalyst was tested for another 235 hours. During this period the catalyst activity remained at about 69% and the amount of chemisorbed ammonia also levelled off. This confirms that catalyst deactivation stops when addition of KCl is ceased.

The catalyst activity as a function of exposure time to K_2SO_4 is shown in Figure 4 (right). The relative activity decreased to 86% during the first 300 hours, corresponding to a deactivation rate of 1.1% per day. Then the relative activity kept decreasing at a rate of about 0.4% per day; i.e. only 40% of the deactivation rate observed for catalysts exposed to KCl at a similar aerosol load. This difference is ascribed to the difference in aerosol particle size since studies with direct impregnation of catalyst with KCl and K_2SO_4 showed these to have equal poisoning effect. Similar to the KCl-aerosol exposure test, the catalyst capacity for NH_3 chemisorption decreased faster than the relative activity. The active sites within the catalyst structure, although not participating in the SCR reaction, react with potassium resulting in a faster decrease in the catalyst capacity for NH_3 chemisorption than the observed activity which is impeded by the mass transfer resistances.

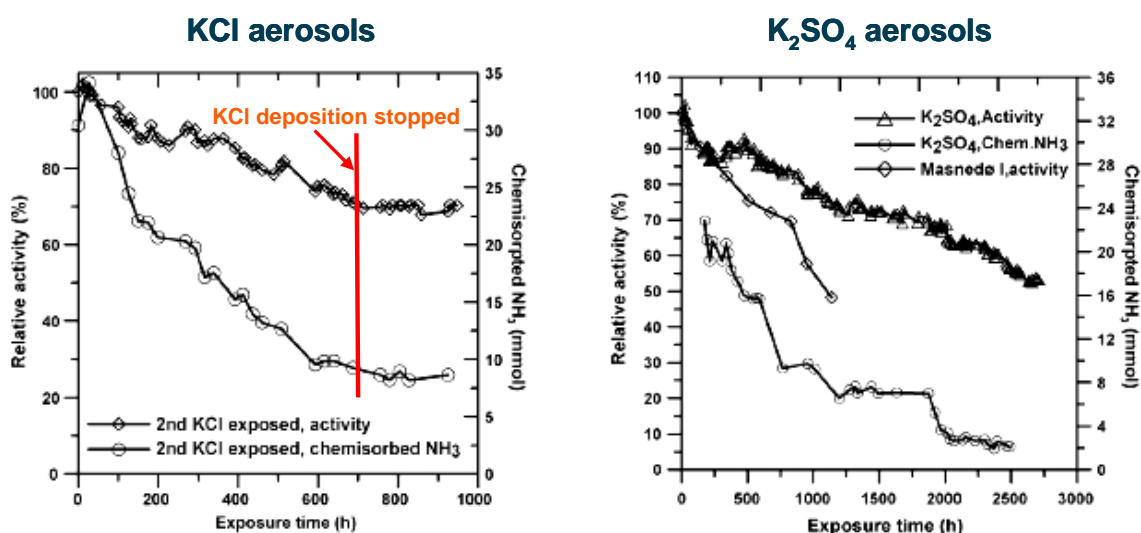

Figure 4 Catalyst activity and chemisorbed NH_3 on the catalyst as a function of exposure time to potassium chloride and potassium sulphate aerosols (from [3])

SEM-EDX analyses showed that potassium partly deposited on the catalyst outer wall but mainly penetrated into the catalyst wall and the NH_3 chemisorption measurements revealed that the Brønsted acid sites had reacted with potassium and were rendered inactive for NH_3 adsorption and subsequent reaction with NO. The conclusion was that chemical poisoning of active sites is the dominating deactivation mechanism but physical blocking of the surface may also contribute to the loss of activity.

Figure 4 (right) shows for comparison the deactivation trend of a catalyst exposed to the flue gas from a straw-fired power plant, Masnedø, in Denmark. The deactivation rate is approximately 50% per 1,000 hours, very similar to what was observed in the KCl-aerosol exposure test.

Figure 5 shows results from activity test and analysis of catalyst samples from a pilot installation on a CFB wood-fired boiler at Nässjö, Sweden. It is seen that at an uptake in excess of 0.2-0.3 % by weight of (soluble) alkali metals, the impact on catalyst activity is very significant and at about 1% an almost complete loss of activity is observed.

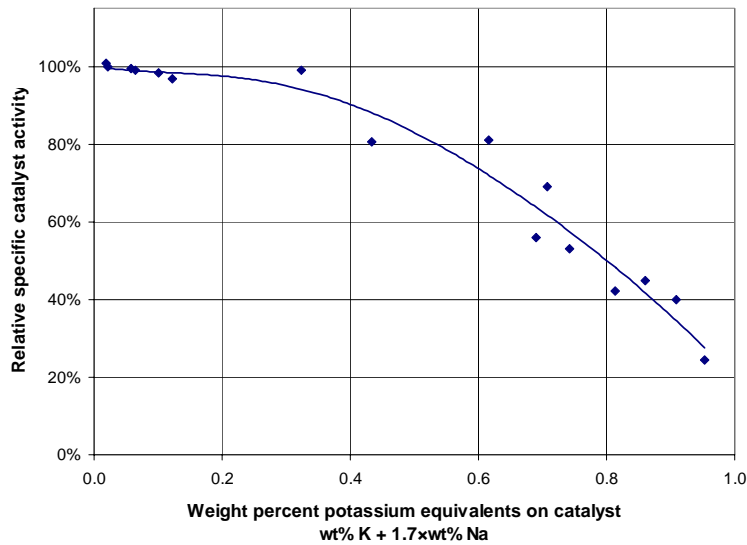

Figure 5 Deactivation of Topsøe DNX[®] SCR catalyst as function of uptake of soluble alkali-metals. Sodium and potassium are weighted according to their molar weight

The conclusion is that chemical poisoning of active sites is the dominating deactivation mechanism, but fouling of the surface area may also contribute to the loss of activity in a practical application.

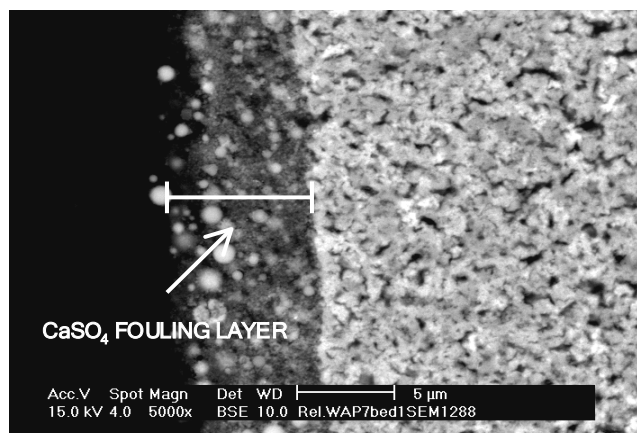

Figure 6 High content of calcium in fuel can cause deactivation of the catalyst in the SCR unit. The scanning electron microscopy picture shows a typical fouling layer on the catalyst surface seen in SCR units firing high-calcium sub-bituminous coals.

Fouling is a physical blockage of the catalyst pore system by aerosols or other sub-micron ash particles. Figure 6 shows how a catalyst exposed to calcium-containing fly ash from burning of sub-bituminous Powder River Basin (PRB) coal has developed a dense layer of calcium sulphate which prevents the NOx in the flue gas to reach the active sites in the interior of the catalyst.

Phosphorous

Organically bound phosphorous in fuel is released as gas-phase phosphorous during the combustion process. The phosphorous reacts in the gas phase to form polyphosphoric-acid aerosols which during cooling-off condenses in the catalyst pores. Reactions with e.g. calcium and alkali metals form sub-micron particles of pyro- or polyphosphates which deposit on the catalyst surface, causing pore blocking and surface masking with an ensuing loss of catalyst activity.

In some cases severe deactivation has been reported. Up to 50% deactivation has been observed after 4,000 operation hours when 5% bone residue or sewage sludge has been co-fired with bituminous coal [4]. These investigations reveal that phosphor seems to accumulate in the catalyst surface.

Figure 7 shows accumulation of phosphorous in the outer 50-100 microns of the wall of a catalyst from a PRB-fired boiler. In this case phosphor penetrates deeper into the catalyst structure than the sub micron calcium-oxide aerosols, which demonstrates that the phosphorous compounds have a high mobility.

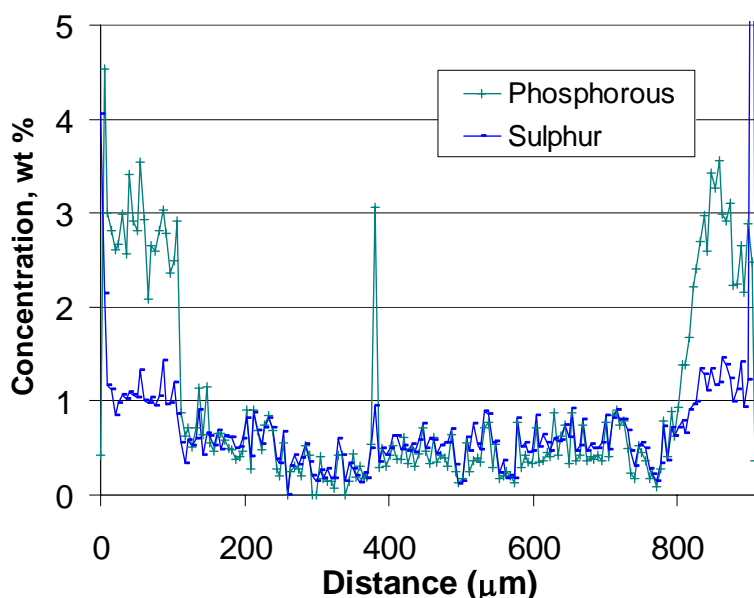

Figure 7 Sub-surface phosphorous layer in the outer 50-100 microns of the surface of a catalyst exposed to flue gas from phosphorous-containing fuel

Arsenic

Arsenic (As) is a component present in most of the world’s coal and co-combustion of e.g. waste and sewage sludge can contribute to fuel arsenic content. When the coal is burned, arsenic is released in the furnace as a gaseous oxide, As_2O_3 . As_2O_3 condenses in the porous catalyst structure and may then block the access to the catalytically active sites. Arsenic in gaseous form can be a main contributor to deactivation of catalysts in SCR DeNOx units on coal-fired boilers.

The susceptibility of the catalyst to poisoning from exposure to arsenic depends strongly on the pore structure of the catalyst. A highly porous catalyst with a diverse pore structure has a high resistance towards arsenic poisoning as the presence of macro-pores ensure access to active sites even when the micro-pores have become plugged by arsenic.

Examples of experience from biomass-fired boilers

DONG Energy, Avedøre Power Station, Denmark

DONG Energy’s Avedøre Power Station Unit 2 is a combined heat and power plant, located in Copenhagen, Denmark. It was commissioned in 2001 and is one of the world’s most efficient power plants with an energy efficiency up to 94%.

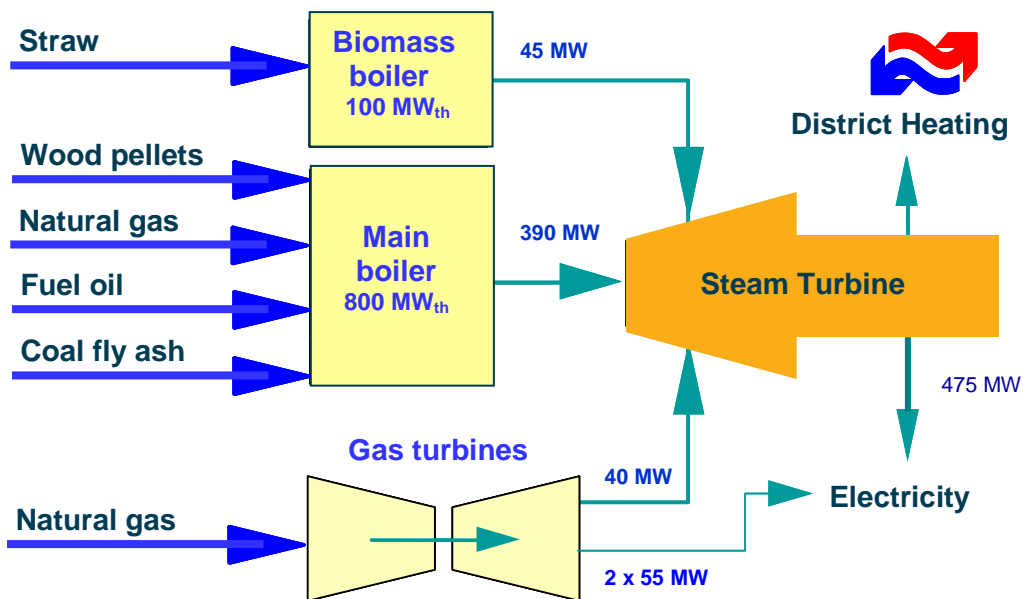

Figure 8 DONG Energy's Avedøre Power Station Unit 2, Denmark [5]

Avedøre Unit 2 uses a multi-fuel concept developed by DONG Energy. The unit consists of an 800 MW_{th} main boiler, a 100 MW_{th} straw-fired boiler and 2x135 MW_{th} gas turbines (see Figure 8). The ultra-supercritical boiler was originally developed to burn natural gas and heavy fuel oil but was retrofitted in 2002 to fire up to 300,000 tonnes per year of pulverised wood pellets as an additional fuel. The furnace is designed for coal firing and has a tangential firing system with sixteen low-NOx burners. The unit is equipped with dust filter, SCR DeNOx and desulphurisation units.

It was experienced [6] that co-firing of wood pellets and fuel oil resulted in deposits in the convective part of the boiler and in the air-preheater. The deposits consisted of alkali from biomass and sulphur and vanadium from the fuel oil. Such deposits are corrosive and catalyses the formation of SO₃. This resulted in plugging of the air-preheater, in corrosion in the electrostatic precipitator and gas preheater as well as deactivation of the SCR.

An accelerated deactivation was expected as the wood's relatively high content of potassium and chloride partly vaporises during combustion, forming a fine aerosol of KCl and K₂SO₄ particles. A catalyst deactivation monitoring programme was initiated. Experience during wood-oil co-firing showed that the catalyst deactivated rather fast as shown in Figure 9.

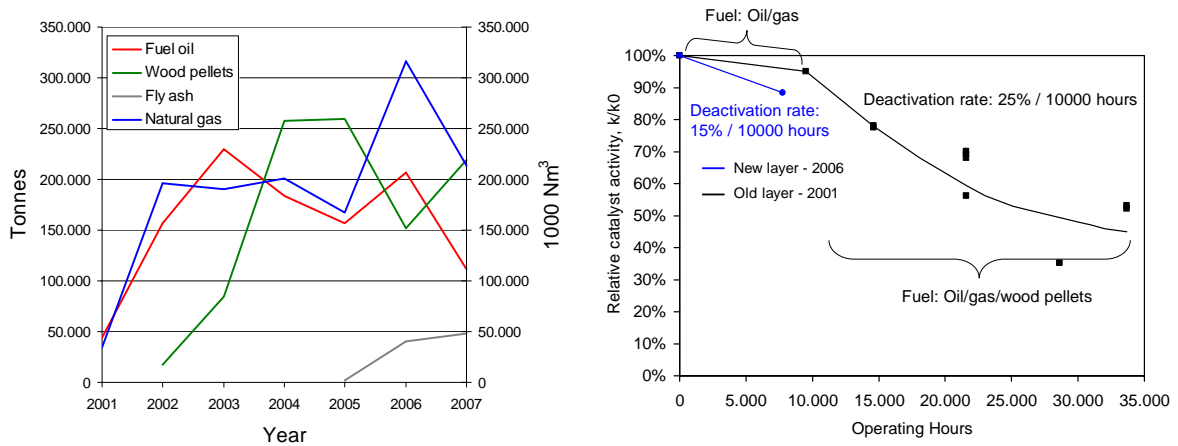

Figure 9 Fuel history and catalyst deactivation on DONG Energy's Avedøre Power Station Unit 2

It was decided to apply washing of the catalyst. The washing process was required to be fast as it would have to be done frequently due to the rapid deactivation. An in-situ washing process using available untreated water was developed to avoid time consuming removal and re-insertion of the catalyst and the outage was reduced to three days [7]. In the following years washing was applied several times per year. However, after three years and consumption of 600,000 tonnes of wood pellets, the activity of the catalyst had been reduced by more than 50%. It was concluded that the washes had not been able to effectively counter deactivation of the catalyst and the catalyst was replaced in 2006 after five years of operation.

To reduce the impact of wood co-firing, injection of coal fly ash into the furnace was initiated in 2006. The fly ash, around six tonnes/hour, is injected through the four “over burner air ports”, above the third burner level. This solved the above-mentioned problems with deposits, and the sulphuric acid aerosols in the stack were also reduced significantly [5]. Furthermore, the coal fly ash to some degree captures wood-ash components that poisons the SCR catalyst such as alkali-metal aerosols, calcium and phosphorous and this has reduced the catalyst deactivation to around 15% per 10,000 hours compared to on average approximately 25% per 10,000 hours before fly-ash injection as shown in Figure 9.

DONG Energy, Studstrup Power Station, Denmark

DONG Energy’s Studstrup Power Station has two 350 MWe PC boilers – Units 3 and 4 – which were put into operation in 1984 and 1985. The units have since then been modernised regularly and in 2002 a conversion to commercial operation with co-combustion of ground straw was initiated. In each of the two units, four out of 24 burners were modified into ground-straw firing by using the core air pipes of the coal-burners for the air/straw suspension. Up to five tonnes/hour of straw can be fired through each burner. With up to 10% co-firing of straw, the fly ash from the units can be utilised in the concrete industry.

Pilot tests

As deactivation of high-dust SCR catalyst is one the critical issues of straw co-firing, slip-stream reactors were installed on Units 3 and 4. An exposure time of 5,000 hours was achieved in the period 2002-2003. On Unit 4 the average straw share was 11% on a weight basis and 7% on energy basis. Unit 3 was 100% coal-fired and the test reactor on this unit was used as a coal-reference for the deactivation tests.

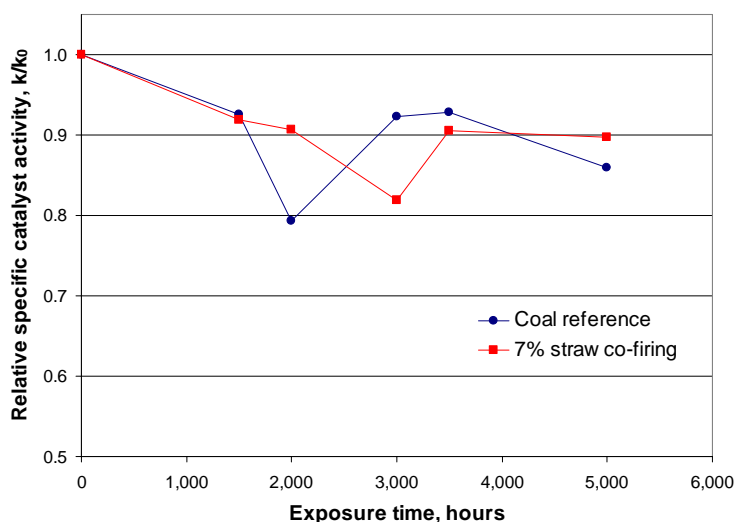

Figure 10 Relative specific catalyst activity as function of exposure time

Three different types of catalysts were investigated. Figure 10 shows the relative specific activity as a function of exposure time for a Topsøe catalyst. There is no distinguishable difference in the deactivation trend from exposure to flue gas from coal-firing and from 7% straw co-firing. The observed deactivation was found to be caused by arsenic and formation of surface fouling layers.

Full scale

In 2007 the two units were retrofitted with SCR DeNOx units with Topsøe DNX[®] catalyst. Shortly after start-up of the DeNOx plant on Unit 4, a rapid increase in pressure drop was observed and inspection of the reactor revealed severe plugging of the catalyst. Detailed investigation of the plugged catalyst showed that the seminal reason was large ash particles, up to 10 mm in length, primarily originating from the knots of the ground straw, cf. Figure 11.



Figure 11 Severe plugging of the SCR catalyst Studstrup Power Station's Unit 4 caused by large straw-ash particles, seen as black particles in the otherwise grey coal ash

The catalyst was unloaded for washing on site. The cleaning was done by submersion of the catalyst modules into hot water, approximately 50°C, combined with aeration (a "hot bubble bath", see Figure 12). The washing was by and large successful, however still leaving some 15-20% of the channels plugged. This could be ascribed to the fact that the fly ash had partly hardened.



Figure 12 Washing of catalyst modules at Studstrup Power Station

To avoid future incidents, fine-meshed screens were built into the flue gas duct at the exit of the boiler to filter out larger ash particles, see Figure 13. The co-firing of straw on Unit 3 had been suspended until sufficient experience had been collected on Unit 4. After five months of satisfactory performance of Unit 4 with no increase in pressure drop across the catalyst, it was decided to equip Unit 3 with similar screens.

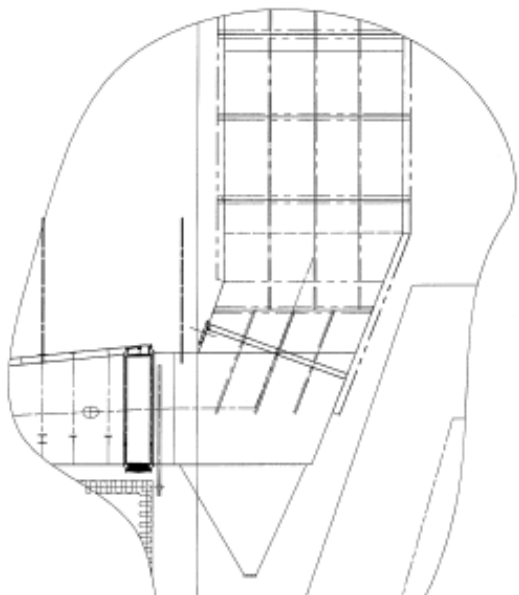

Figure 13 Installation of large particle ash screens in the flue gas duct on Studstrup Power Station Units 3 and 4 (adopted from [8])

Electrabel, Langerlo Power Station, Belgium

Electrabel operates two identical 250 MWe coal-fired boilers at their Langerlo Power Station at Genk, Belgium. The two boilers were originally (in the mid 1970ies) constructed as oil-fired boilers but were converted to coal firing in 1985-86. As part of the so-called Langerlo 2000 Environmental Project the two units were retrofitted with flue-gas desulphurisation and SCR DeNOx systems in the late 1990ies.

Since 2003 biomass has been co-fired with the coal and the amount now constitutes 10-20% on mass basis. On average the fuel blend is composed of 86% coal, 3% olive residue, 4% dried sewage sludge and 7% wood dust from hardboard production. Two thirds of the coal fired is low-alkali South African coal to limit the overall alkali content of the fuel blend. Table 3 shows the fuel and ash analyses. It is seen that the biomass contributes significant amount of phosphorous and alkali metals. Sewage sludge contains high sulphur levels and heavy metals can be in high concentrations. Sewage sludge also has much higher ash content than biomass and to avoid problems with slagging and to maintain ash quality, co-firing rate is generally limited.

Proximate analysis		South African	US CONSOL	Sewage sludge	Olive residue	Wood	Blend
Moisture	% wet	8.45	6.61	8.18	15.95	5.45	7.90
Ash	% dry	14.83	8.18	45.07	10.82	1.12	12.81
Volatiles	% dry	24.01	38.35	47.93	72.79	79.15	34.47
Lower heating value	kJ/kg	25,045	29,109	10,727	15,910	17,368	24,951
Hardgrove index	HGI	53	55	40			
Ultimate analysis							
Carbon, total	% dry	71.49	77.17	30.58	46.76	47.74	69.36
Hydrogen	% dry	3.93	5.21	7.50	5.95	5.90	4.64
Oxygen	% dry	7.49	5.80	13.98	34.66	37.20	10.10
Nitrogen	% dry	1.67	1.43	0.54	1.22	7.88	1.98
Sulphur	% dry	0.59	2.21	1.54	0.06	0.07	1.06
Chlorine	ppm dry	30	930	1100	10,000	160	646
Fluorine	ppm dry	211	83	300	107	71	163
Ash analysis							
SiO ₂	% dry	50.56	44.80	41.00	28.93	8.20	47.47
Al ₂ O ₃	% dry	38.91	22.70	13.00	3.00	20.45	31.59
TiO ₂	% dry	2.27	1.03	1.10	0.20	44.50	2.1
Fe ₂ O ₃	% dry	3.42	19.10	11.00	3.94	8.02	7.4
CaO	% dry	1.20	4.35	13.00	23.28	8.65	3.9
MgO	% dry	0.25	0.97	1.50	12.80	2.68	0.87
K ₂ O	% dry	0.77	1.58	1.70	17.34	2.46	1.47
Na ₂ O	% dry	0.07	0.98	1.50	4.54	1.06	0.54
P ₂ O ₅	% dry	1.28	0.39	12.0	3.4	16.6	2.6
As	ppm dry						35

Table 3 The fuel blend fired at Electrabel's Langerlo Power Station, Belgium

At the annual stops catalyst elements have been taken for chemical analysis and activity tests. Figure 14 shows the catalyst deactivation trend over a period of 55,000 operating hours.

It is remarkable that the activity has stabilised at a level around 75% but this is in good accordance with a deactivation model developed at Haldor Topsøe. After an initial deactivation period, the deactivation almost ceases. The arsenic content in the catalyst increased with operating time until a level of 0.25% by weight at which no further uptake occurred, corresponding to establishment of equilibrium with the flue gas concentration of gaseous arsenic. This level of arsenic has only a marginal influence on the activity of the high-porosity Topsøe catalyst.

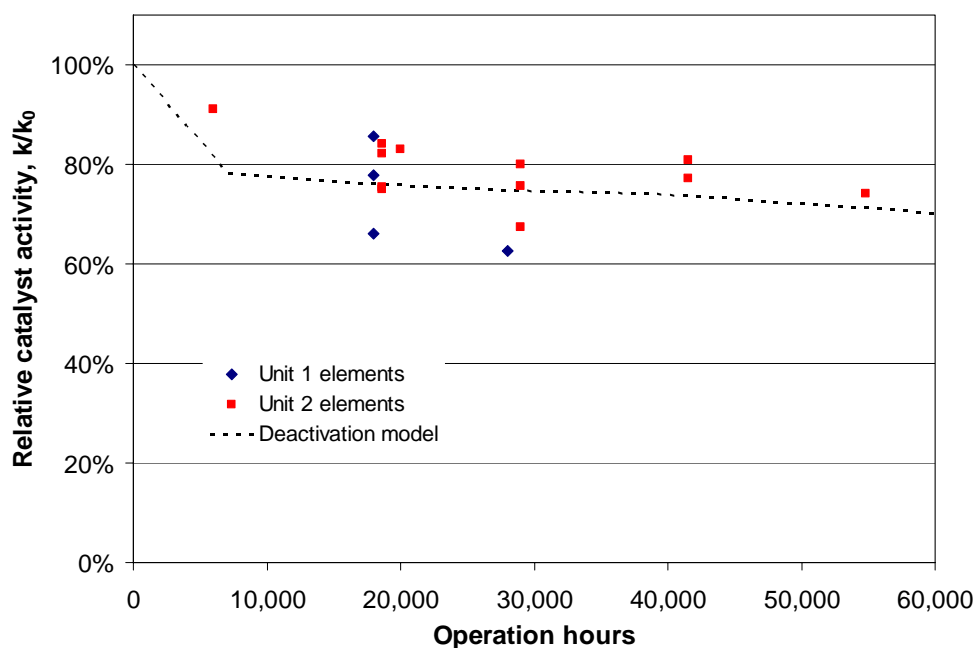

Figure 14 SCR catalyst deactivation at Electrabel's Langerlo Power Station, Belgium

Likewise, chemical analyses have shown only a very modest uptake of alkali metals, around 0.2% by weight sodium plus potassium, and less than 0.1% by weight phosphorous has been found. After the initial accumulation, these levels have been constant and do not differ from what can be observed in catalyst on 100% coal-fired units. A slight fouling of the catalyst surface with fly ash seems to function as a 'passivating' layer in which the alkali metals have low mobility.

Vattenfall, Combined Heat and Power, Sweden

Uppsala CHP is a 400 MW_{th}/125 MW_e combined heat and power plant located in Uppsala, Sweden. In 2005, the existing SNCR was retrofitted with an up-flow high-dust SCR unit equipped with Topsoe DNX[®] catalyst. The pulverised-fuel boiler is 100% biomass fired, burning

peat and up to 30% wood dust. The plant is operating 2-3,000 hours per year during winter seasons when there is a demand for heat.

Catalyst samples were tested in 2007 and 2008 after the first two seasons. The measured residual activity is shown in Figure 15. It is seen that during 5,000 operating hours the catalyst has lost 37% of its activity, corresponding to an exponential deactivation rate of 60% per 10,000 hours.

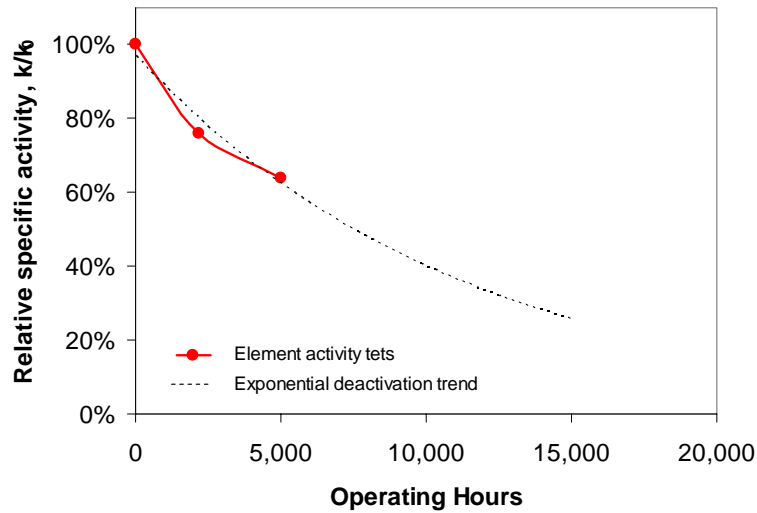

Figure 15 SCR catalyst activity versus operating hours after 5,000 hours in Vattenfall's Uppsala CHP

The peat and wood contain 1-2 wt% potassium and around 1 wt% phosphorous in the ash. Chemical analysis of catalyst samples showed only a modest uptake of soluble alkali metals (around 0.1 wt%) whereas 0.5-0.8 wt% iron and 0.2-0.4 wt% magnesium was found. The content of phosphorous had increased gradually from 0.26 wt% after 2,000 hours to 0.66 wt% after 5,000 hours. The phosphorous was found primarily in the outer 200 microns of the catalyst wall at a level up to 1 wt%, cf. Figure 16.

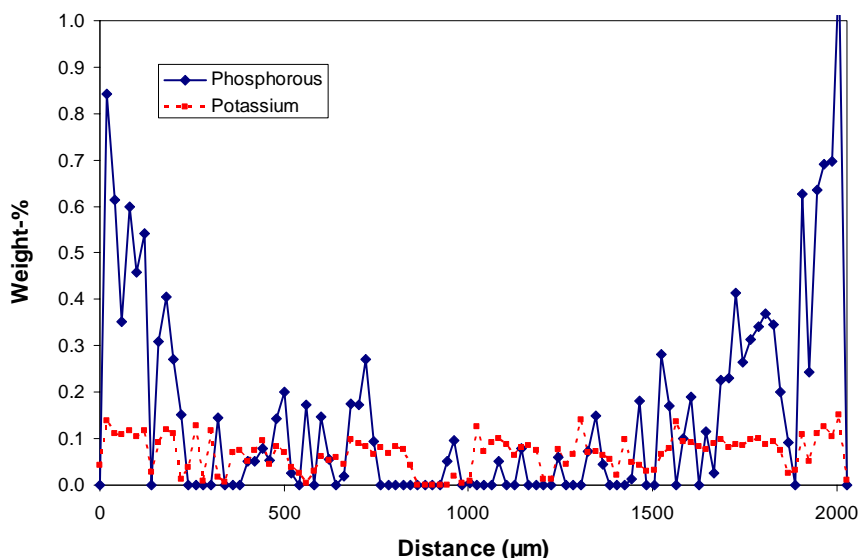

Figure 16 Example of distribution of phosphorous and potassium through the catalyst wall of a catalyst sample from Vattenfall Uppsala CHP, Sweden. The phosphorous is predominantly found at the surface.

Sierra Power, California, USA

Sierra Power Corporation in Terra Bella, California, USA operates a small 9 MW grate-fired boiler at a saw mill, fuelled by wood and demolition wood. The plant provides a disposal site for local green waste lumber manufacturers and pallet manufacturers. The plant started up in 1986. In 2008 the plant was retrofitted with SCR DeNOx located downstream a cyclone.

A catalyst element was tested after 3,000 operating hours. The element was covered with fine ash and was mechanically cleaned with air before testing. The activity showed 93% activity relative to the fresh catalyst, corresponding to a deactivation rate of 22% per 10,000 hours. This is far lower than the deactivation rate of 60% per 10,000 hours experienced for the pulverised-fuel boiler at Uppsala CHP described above.

Chemical analysis revealed that the catalyst had accumulated more than 1% by weight soluble potassium and also minor amounts of sodium (Table 4). It was therefore decided to test washing of the catalyst in hot water to possibly remove the alkali-metal salts. The washing resulted in more than 60% reduction of the alkali metal content. Surprisingly, however, the catalyst activity dropped from 93% for the air-cleaned catalyst to 79% for the water-washed catalyst.

Service hours	0	3,000	
		Air cleaned	Water washed
Catalyst activity % relative to fresh	100	93	79
Potassium, mg/kg	200	12,720	4,820
Sodium, mg/kg	500	1,760	500
Phosphorous, wt %		0.33	0.25

Table 4 Catalyst activity and chemical analysis of catalyst from Sierra Power, USA

It is concluded that grate-firing of biomass does not evaporate alkali metals and release the salts as aerosols to the same degree as does pulverised-fuel or CFB firing and thus that this boiler type causes less SCR catalyst deactivation, cf. Table 2. Rather, the alkali-metal salts are found as larger particles with other ash constituents which may deposit on the outer surface of the catalyst. This explains the rather modest decrease in activity for the Sierra Power catalyst in spite of accumulation of more than 1 wt% potassium. Washing of the catalyst results in dissolution of the salts and transport to the catalyst interior (see Figure 17) and bonding to the vanadium active sites. The residual activity of 79% is in fair accordance with the potassium level of around 0.5%, cf. Figure 5.

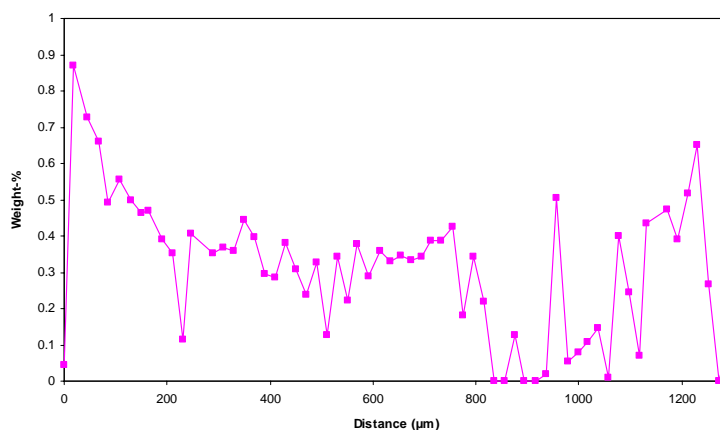

Figure 17 Potassium profile through the catalyst wall after water washing

Vattenfall, Amager Power Station, Denmark

Vattenfall's Amager Power Station in Copenhagen, Denmark has three units that are all producing electric power to the grid and district heating. Units 1 and 2 were originally identical and taken into service in 1970/1971. Unit 3 was taken into service in 1991. Since 2004 Unit 1 has been out of service and the turbine, the boiler and the environmental control systems are being replaced. Wet flue gas desulphurisation and SCR system including a regenerative gas-gas heat

exchanger has been supplied by Alstom [9]. The upgraded Unit 1 will have a firing capacity of 350 MJ/s and be in service again in 2009.

The unit has been designed to be very flexible regarding fuel mix and can burn coal, pelletised straw, wood pellets, or coal-biomass in an arbitrary mixture. Fuel oil can be used as start-up or emergency fuel. The straw has high potassium and low ash contents with the potential of a rapid deactivation of the SCR catalyst, cf. Table 2. Comparing the composition of ashes from coal and from straw it is seen that the potassium content differ one order of magnitude (Table 5), also on an energy basis (Table 6).

	Reference coal	Straw
SiO ₂	47	30-60
Al ₂ O ₃	31	0.4-1.7
Fe ₂ O ₃	6.3	0.3-1.0
CaO	4.2	7-14
MgO	1.7	1.7-2.3
TiO ₂	1.1	-
Na ₂ O	0.9	0.4-1.2
K ₂ O	2.0	14-29

Table 5 Composition of coal and straw ashes (% by weight)

		Reference coal	Straw
LHV	MJ/kg	22.8-26.2	15
Ash content	% by weight	6-18	4.5
K ₂ O in ash	% by weight	2.0	14-29
K ₂ O per MJ	g/MJ	0.046 – 0.137	0.42 – 0.87

Table 6 Ash content of potassium on basis of fuel energy content

To enable coal-straw co-firing in any desired ratio, the SCR DeNOx system was chosen as a tail-end installation, located downstream the ESP and wet FGD to minimise the amount of harmful ash constituents reaching the SCR reactor (Figure 18).

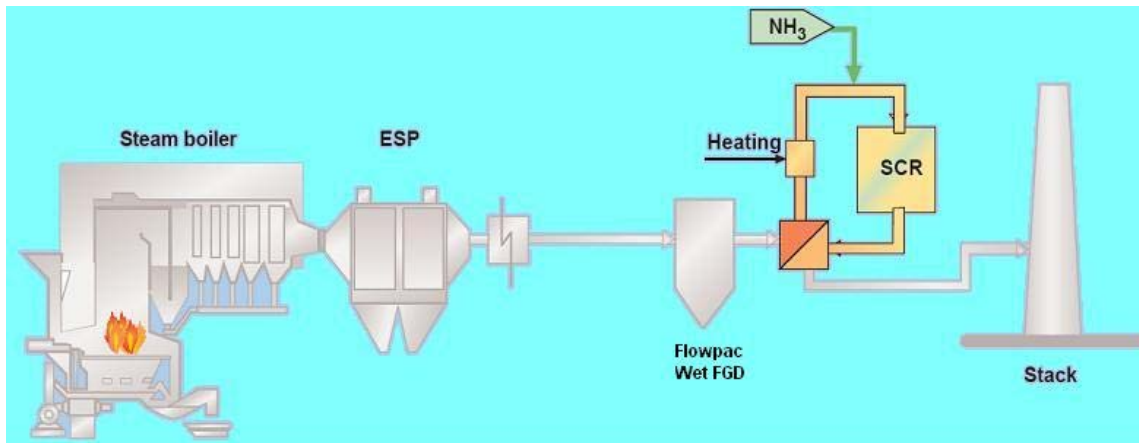

Figure 18 General layout of Vattenfall Amager Power Station Unit 1 (from [9])

Conclusions

Direct co-firing of biomass with fossil fuel is a simple and widely applied technology for combining renewable and fossil energy utilisation to reduce CO₂. However, the release of alkali-metal aerosols formed during combustion and phosphorous ash can cause rapid deactivation of SCR catalysts. The experience from a number of installations of Topsøe's DNX[®] catalyst shows that:

- Co-firing of up to 20% biomass can be done without causing extraordinary deactivation of the catalyst compared to 100% coal firing.
- For 100% biomass firing the deactivation rate can be as high as 60% per 10,000 hours in a pulverised-fuel fired boiler. In a grate-fired boiler the deactivation rate is lower, 22% per 10,000 hours, presumably because less alkali-metal aerosols are released.
- It is not possible to remove alkali metals bonded to the catalyst's active sites by simple water washing. On the contrary, alkali-metal salts deposited in the outer surface of the catalyst may be transported to the interior, causing additional deactivation.
- The formation of large-particle ash (LPA) during combustion of biomass must be considered, necessitating installation of LPA screens.
- The use of SCR on 100% biomass-fired boilers may be done as a tail-end installation to minimise the amount of poisoning species entering the SCR.
- Injection of coal fly ash in a wood-fuel oil co-fired boiler can reduce problems with deposits in the convective part of the boiler and in the air-preheater and significantly reduce catalyst deactivation rate by capturing poisonous constituent of the wood ash.

References

1. Topsøe, N.Y, Infrared Spectroscopic Investigations of Environmental DeNOx and Hydrotreating Catalysts, Doctoral dissertation, Technical University of Denmark (1998)
2. Christensen, K.A., The formation of submicron particles from the combustion of straw, Ph.D. thesis, Technical University of Denmark (1995)
3. Zheng, Y., A. D. Jensen, J. E. Johnson, J. R. Thøgersen, Deactivation of V_2O_5 - WO_3 - TiO_2 SCR catalyst at biomass fired power plants, Appl. Catal. B, 83 (2008), 186
4. Brandenstein, Actual state of knowledge, Catdeact project, E.ON. engineering GmbH (2002)
5. Jensen, J. P., H. D. Sørensen, J. Hansen, S. L. Christensen, Deactivation of high dust deNOx catalyst when co-combusting heavy fuel oil and biomass, Electric Power Conference, Chicago 2007
6. Berg, M. and J.P. Jensen, Biomass and secondary fuels in Denmark, VGB Power Tech (2008)
7. Pedersen, L. S., A. D. Jensen, Selective catalytic reduction of NO in a biomass-fired full scale PF boiler, Dansk Kemiingeniørkonference, Copenhagen, June 2006
8. Bille, T., Biomass co-firing, development and experiences with operation, Expperts Conference, Brussels (2008)
9. Crespi, M., M. Porle, A.-C. Larsson, R. La Civita, A. R. Nielsen, The influence of biomass burning in the design of an SCR installation, Power-Gen Europe (2008)

Presented at Power-Gen Europe, Germany, 2009

Best paper award within the conference track 'Coal, Nuclear & Biomass Generation'