

Urea-SCR Catalyst System Selection for Fuel and PM Optimized Engines and a Demonstration of a Novel Urea Injection System

Ioannis Gekas, Pär Gabriëlsson and Keld Johansen
Haldor Topsøe A/S

Lars Nyengaard
Grundfos Management A/S

Thomas Lund
Dansk Teknologi A/S

Copyright © 2002 Society of Automotive Engineers, Inc

Reprinted with permission from SAE International. This paper may not be photocopied, e-mailed or otherwise reproduced without permission of SAE International

ABSTRACT

This paper discusses the choice of catalyst types to reduce the NO_x emissions down to the Euro V level. A novel Urea injection system is also presented, which is based on a mass produced digital dosing pump that is combined with an electronic control unit specially developed for controlling the Urea-SCR process onboard vehicles. It is shown that it is possible to have a NO_x conversion above 80% with ammonia slip below 10 ppm using 30 liters of 130 cpsi catalysts for a 12 diesel engine. By increasing the cell density to 300 cpsi it is possible to reduce the catalyst volume by 2/3 down to 20 liters for the same engine.

INTRODUCTION

In order to comply with the Euro V regulations for heavy-duty diesel engines due in 2008, both the NO_x and particulate emissions must be greatly reduced for today's state of the art diesel engines. The regulations of 2008, namely 2.0 g/kWh NO_x and 0.02 g/kWh particulate, cannot be achieved solely by engine management or improved engines, rather some sort of after treatment must be used. One solution is to use a particulate trap to reduce soot emissions together with some sort of NO_x-reducing aftertreatment preferably Urea SCR. The Urea SCR systems have been shown to be both very efficient and durable in vehicle applications [3,4,5,6].

However, there is another solution to reduce the NO_x and PM emissions that seems very promising. Using engine modifications a diesel engine can be optimized to give very low particulate emissions, below the 0.02g/kWh limit of 2008 [1]. These modifications of the engine inevitably lead to higher NO_x emissions from today 7-8 g/kWh to 9-11g/kWh. A Urea SCR after treatment

system can then be used to bring down the NO_x emissions to below 2.0g/kWh. This requires a reducing capacity of the SCR system of 80-85% [2]. If this could be achieved, then an optimized engine described above together with the SCR system would be sufficient to meet the regulations, eliminating the need of a particulate trap. The advantages of this system are evident, lower cost and size of the after treatment system. Also one very big advantage of this solution is that an optimized engine with low particulate and high NO_x emissions also has a lower fuel consumption than that of a regular engine. The fuel saving is in the order of 3-5%, a very significant amount for any potential customer [1].

This article describes a Urea-SCR system optimization. Different catalysts and catalyst combinations were tested, both under stationary and transient operation of the engine in order to find a suitable catalyst for the task. The catalysts used were standard Urea-SCR catalysts (hereinafter called DNX) of various volumes and SCR catalysts combined with slip oxidation catalysts using Pd and Pt, (hereinafter called DNX-Pd and DNX-Pt) and some combinations with a pre-oxidation catalyst combined with DNX with and without a slip oxidation catalyst. Combinations of urea SCR catalysts and pre-oxidation have been reported to be efficient in increasing the low temperature activity of the Urea SCR process [2].

As mentioned above, an optimized engine is estimated to have base-NO_x emissions of 9 to 11g/kWh. The system chosen should therefore have a NO_x reducing capacity of at least 80%, preferably more in order to achieve the EuroV NO_x emission legislation of 2.0 g/kWh. This capacity should be achieved during both stationary and transient test cycles like the ETC and ESC. Furthermore the system is not to have large ammonia slip while achieving the high NO_x-conversion.

In order to achieve a high conversion degree with minimal NH_3 slip, below 10 ppm on average, it is of utmost importance that the injection system has a high precision and is able to respond very quickly. Therefore, a novel urea injection system was developed based on a mass produced metering pump, which was combined with a Urea-SCR ECU.

EXPERIMENTAL

CATALYST TEST SETUP

The different catalyst combinations to be tested are schematically illustrated in figure 1.

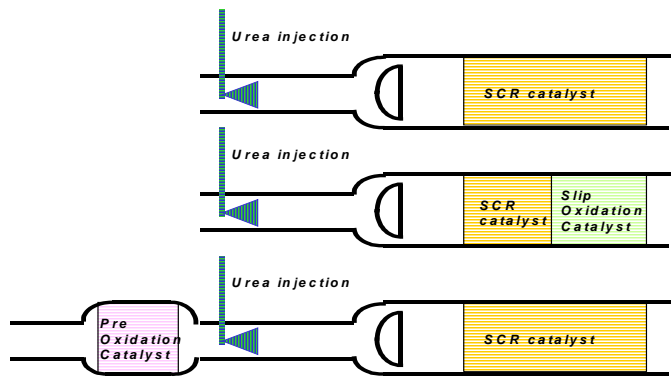

Figure 1. Different catalytic setups.

The first case corresponds to pure urea SCR catalyst, of different volumes.

In the second case a slip oxidation catalyst is introduced behind the Urea-SCR catalyst. The function of the slip oxidation catalyst is to remove excess NH_3 that slips past the SCR catalyst. Because a design target of the catalyst system is to have low NH_3 slip, the addition of a slip oxidation catalyst can enable a larger injection of urea and consequently a higher conversion of NO_x .

In the third case a pre-oxidation catalyst is introduced in front of the main SCR catalyst that may consist of a combination of SCR and slip-oxidation catalyst as in the second case above.

The injection of urea has to take place after the pre-oxidation catalyst, otherwise the urea injected would be oxidized over the pre-oxidation catalyst and would never reach the SCR catalyst. The function of the pre-oxidation catalyst is to oxidize hydrocarbons from the engine and also convert NO to NO_2 . NO_2 is more active than NO in the SCR reaction and a higher activity can be achieved on the SCR catalyst with a higher NO_2 to NO ratio. A summary of the catalysts used in the engine test is presented in Table 1 below. All SCR catalysts (DNX) had diameters of 393 mm and the oxidation catalyst (CKM) had a diameter of 235 mm.

Table 1. DNX urea-SCR catalysts used in engine tests

Catalyst name	Cell dens. (cpsi)	Volume (liter)	Active material
DNX15	130	15	V/TiO ₂
DNX30	130	30	V/TiO ₂
DNX45	130	45	V/TiO ₂
DNX15-Pd	130	15	V, Pd/TiO ₂
DNX15-Pt	130	15	V, Pt/TiO ₂
CKM	130	8	Pt/Al ₂ O ₃

ENGINE

The engine used was a 12 liter 400 hp HD diesel engine calibrated for the Euro II emission standard and certified by the ECE-R49 test cycle.

The fuel used was Swedish Environmental Class 1 having less than 10 ppm sulfur and less than 5 vol-% aromatics.

UREA INJECTION SYSTEM

The injection system uses a unique, digital dosing pump, which is a slightly modified Grundfos DME8 metering pump. The digital dosing product concept is known from the metering business and is easily converted to the automobile industry for the injection of a Urea-water solution into the exhaust pipe. The mass produced digital dosing pumps have a fully digitized, versatile interface, allowing them to be controlled by various means, e.g. CAN-bus or high-precision analog signals. The digital dosing pump concept is a diaphragm metering pump, with the diaphragm directly coupled to the stepper motor. This allows the metering pump to have a high accuracy over the entire capacity range (1:1000), virtually independent of the back pressure in the system. The digital dosing pump has been combined with an electronic control unit, ECU, specially developed for controlling the Urea-SCR process onboard vehicles. A picture of the combined digital dosing pump and the electronic control unit specially developed to control Urea-SCR process onboard is seen in Figure 2.



Figure 2. Combined Urea-SCR ECU and digital dosing pump

The complete urea injection system consists of the combined digital dosing pump and Urea-SCR ECU, a valve manifold, a storage tank and a urea/air atomizer. Previously, a urea-injection system using a urea injection valve combined with a pressurized tank system was used [3]. However, this system had problems with long-term dosing stability and often, new calibrations of the dosage of urea had to be made on a daily basis. With the digital dosing pump system these problems were eliminated and the initial pump calibration lasted for the whole testing period of approximately three months.

The dosing pump shows short time variations when dosing. As a set point of 30g/min is set to the pump the actual output varied between 25 and 35g/min. However these short time variations are rapid enough as to not affect the conversion of NO_x over the catalyst. More important was that the mean value of the actual injection over time was very stable and reproducible.

The dosing pump was also able to follow the rapidly changing set points given by the electronic control unit, ECU, during the transient cycles. This is illustrated for a ETC cycle in Figure 3.

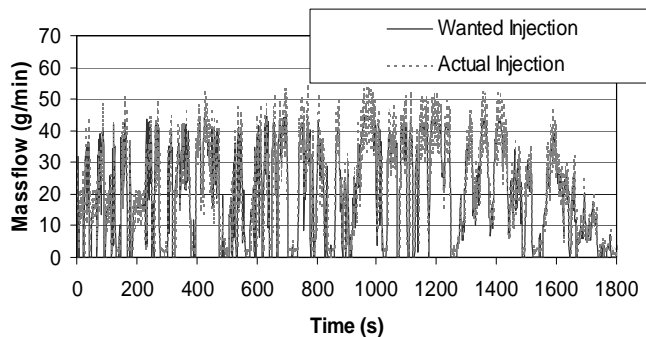

Figure 3. Wanted and actual injection during an ETC cycle.

Laboratory tests as well as engine test cell tests show that the pump has a high cycle to cycle repeatability. In Figure 4 three repetitions of the European Transient Test cycle are shown and it can be seen that there were practically no variations in accumulated urea dosage over these three cycles.

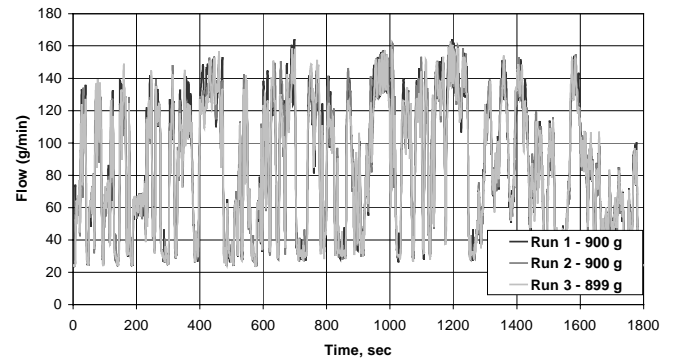

Figure 4. Reproducibility of the urea injection system

The urea injection was controlled by real time kinetic calculations carried out in an electronic control unit, Urea-SCR ECU, which uses various sensors as input for the calculations as described in Figure 5 below.

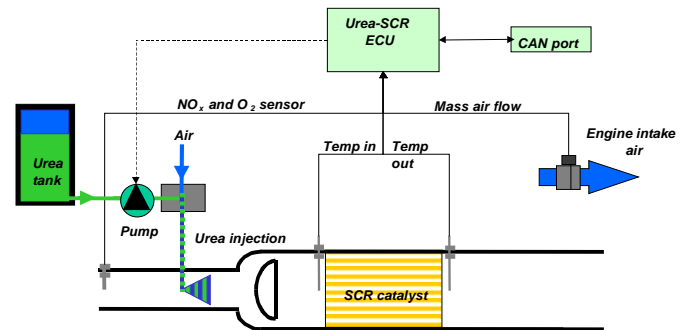

Figure 5. Urea injection control system

STATIONARY TESTS

In order to calculate the activity of the different catalysts/catalyst combinations, stationary tests were conducted for two different engine speeds at different temperatures. The speeds chosen were 1100 and 1800 rpm. For each speed, four temperatures were tested, 200, 250, 300 and 400°C. Urea was injected to achieve high NH₃/NO_x ratios above 1.1 and the NO_x-conversion and NH₃-slip were measured in order to assure that deficit in NH₃ did not limit the reaction.

DNX15, DNX30 AND DNX45

The NO_x-conversions obtained with 15, 30 and 45 liter of only DNX catalysts at temperatures between 200 and 400° C with NH₃/NO_x dosing ratio = 1.1/1 and stationary conditions are shown in Figures 6 (1100 rpm) and 7 (1800 rpm).

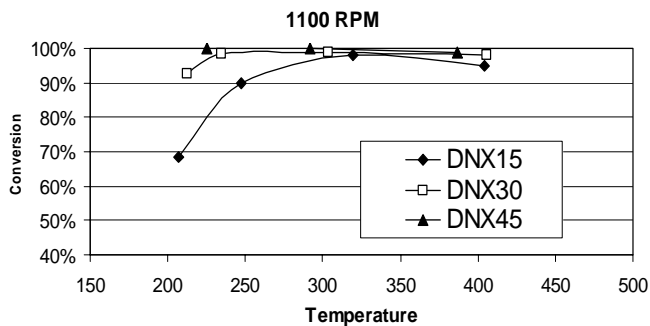

Figure 6. NOx reduction as a function of temperature at a NH₃/NO_x ratio of 1.1/1 and at 1100 rpm for pure Urea-SCR catalyst.

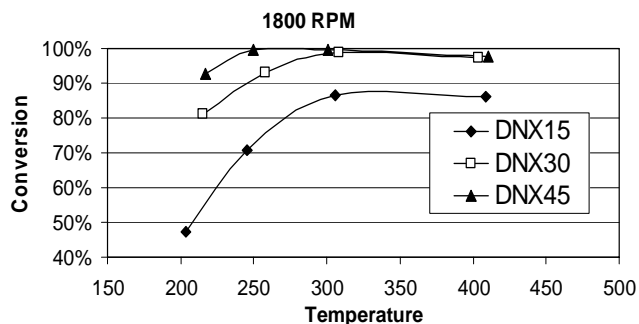

Figure 7. NOx reduction as a function of temperature at a NH₃/NO_x ratio of 1.1/1 and at 1800 rpm for pure Urea-SCR catalyst.

At the lower engine speed 1100 rpm, i.e. lower exhaust flow and lower NHSV (Normal Hourly Space Velocity), nearly 100% NO_x-conversion is achieved with the 30 and 45 liter of DNX catalysts in the whole temperature range of 200-400°C. With 15 liters of DNX, nearly 100% NO_x conversion is obtained above 300°C while the conversion decreases below 300°C reaching 64% at 200°C.

With higher engine speed and, thus, higher NHSV, the different catalyst volumes play a more significant role in achieving high conversions. 45 liters of catalyst, DNX45, still convert almost all NO_x over the whole temperature range, apart from at very low temperatures. DNX30 reaches 100% conversion at 300°C but gives lower conversions at lower temperatures compared to the DNX45 catalyst. Finally, the DNX15 catalyst is too small for this application and cannot achieve high NO_x conversions even at 300°C.

SLIP OXIDATION CATALYSTS DNX-PT, DNX-PD

The two different 15 liters of slip oxidation catalysts, DNX15-Pd and DNX15-Pt, were tested in combination with the DNX15 catalyst mounted upstream of the slip oxidation catalyst, as shown in Figure 1.

The results of the conversion of NO_x at 1,1/1 NH₃/NO_x dosing ratio as a function of temperature from the

stationary tests are presented in Figure 8 (1100rpm) and 9 (1800rpm).

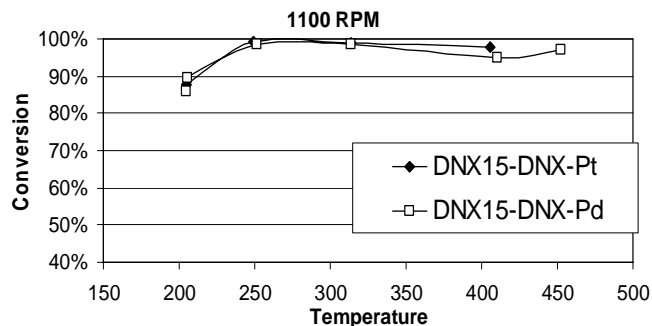

Figure 8. NOx reduction as a function of temperature at a NH₃/NO_x ratio of 1.1/1 and at 1100 rpm for Urea-SCR catalyst combined with oxidative Urea-SCR catalyst.

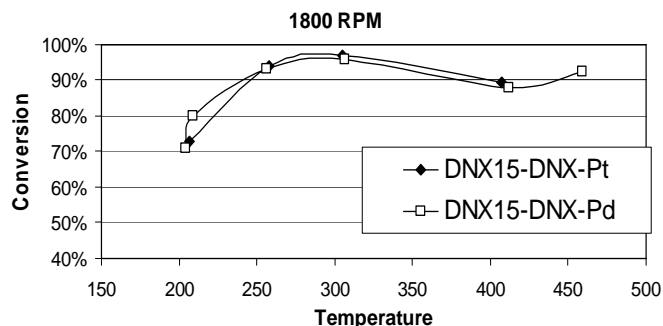

Figure 9. NOx reduction as a function of temperature at a NH₃/NO_x ratio of 1.1/1 and at 1800 rpm for Urea-SCR catalyst combined with oxidative Urea-SCR catalyst

At both low and high engine speeds, both DNX15 coupled with DNX15-Pd or DNX15-Pt slip oxidation catalysts have almost the same NO_x conversion capacity. Both catalyst combinations have high conversions of NO_x over the whole temperature range. For the high engine speed it can be seen that both catalyst combinations have a drop off in NO_x conversion for temperatures higher than 300°C. This effect was not experienced with the “pure” DNX catalysts. It is believed that oxidation of excess NH₃ causes this drop off in NO_x conversion over the slip oxidation catalyst at high temperatures. Some of the ammonia oxidized forms NO_x and therefore lowers the apparent conversion. This effect is noticeable also at lower engine speeds, but less pronounced.

PRE-OXIDATION CATALYST

Tests were made with a catalyst combination of pre-oxidation catalyst, called CKM, together with the DNX15 and DNX15-Pd slip-oxidation catalysts and are compared to the tests of DNX15 and DNX15-Pd catalyst without pre-oxidation catalysts (catalysts are explained in Table 1). The results of the conversion of NO_x at 1,1/1 NH₃/NO_x dosing ratio as a function of temperature from the

the stationary tests are presented in figure 10 (1100rpm) and 11 (1800rpm).

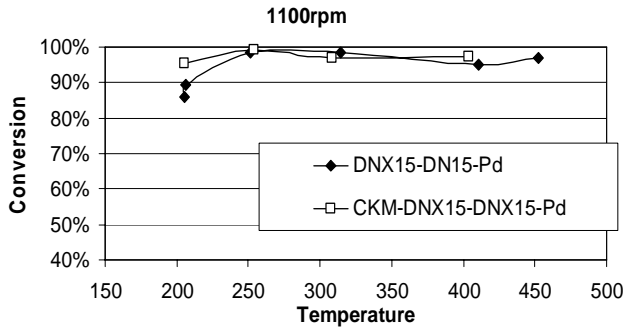

Figure 10. NOx reduction as a function of temperature at a NH₃/NO_x ratio of 1.1/1 and at 1100 rpm for Urea-SCR catalyst combined with oxidative Urea-SCR catalyst with and without pre-oxidation catalyst.

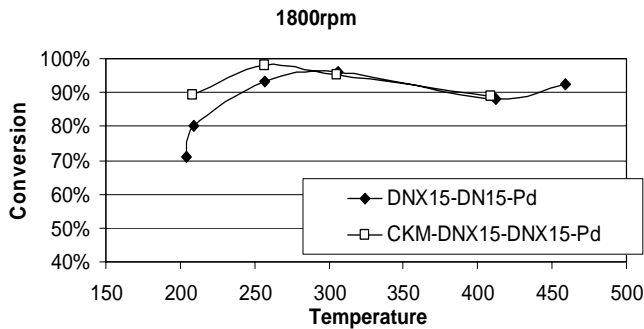

Figure 11. NOx reduction as a function of temperature at a NH₃/NO_x ratio of 1.1/1 and at 1800 rpm for Urea-SCR catalyst combined with oxidative Urea-SCR catalyst with and without pre-oxidation catalyst

The positive effect of the pre-oxidation catalyst is evident at low temperatures, i.e. 200-250°C for both high and low engine speeds. However, this gain in activity is achieved at the expense of more overall catalyst volume and also larger space required by the catalytic system, since Urea has to be introduced and distributed between the two monoliths.

TEST CYCLE TESTING

SCREENING TEST USING THE ETC TEST CYCLE

Due to the large number of catalyst combinations available it was not realistic to run extensive transient testing and optimization for all the catalyst combinations. The goal was to find a suitable catalyst combination and thereafter optimize the injection strategies for the chosen catalyst. A few transient tests were therefore conducted for all catalyst combinations in order to elucidate which ones could achieve the desired high NO_x conversions of 80-85% and at the same time have a low NH₃ slip.

The catalyst combinations that could achieve the criteria of having more than 80% NO_x reduction without any significant NH₃ slip were DNX45, DNX15+DNX15-Pd and DNX15+DNX-Pt. Adding the CKM pre-oxidation catalyst to any of these three combinations would also make a suitable combination. The DNX30 catalyst was on the verge of achieving the criteria. For the DNX15 and also CKM+DNX15 the NO_x conversion achieved was not sufficient.

CHOICE OF CATALYST

From the three suitable candidates the DNX15 and DNX15-Pd combination was chosen for further testing. The DNX45, although having the best results of all catalyst combinations, was not chosen because of the high volume. Due to space considerations it was preferable to have maximum around 30 l of catalyst. The DNX15 and DNX15-Pd or DNX15-Pt showed identical performances. The reason for not choosing DNX15 and DNX15-Pt catalyst combination was that the DNX15-Pd slip oxidation catalyst is a standard catalyst for our company whereas DNX15-Pt is regarded as an experimental one.

TRANSIENT TESTS WITH DNX15+DNX15-PD CATALYST

Several ETC cycles were run with the DNX15+DNX15-Pd catalyst combination in order to optimize the injection strategy. An example from such an ETC cycle can be seen in Figure 12. In this ETC cycle the base emission of 8 g/kWh NO_x is brought down to 1.45g/kWh with a mean NH₃ slip of 7.5 ppm.

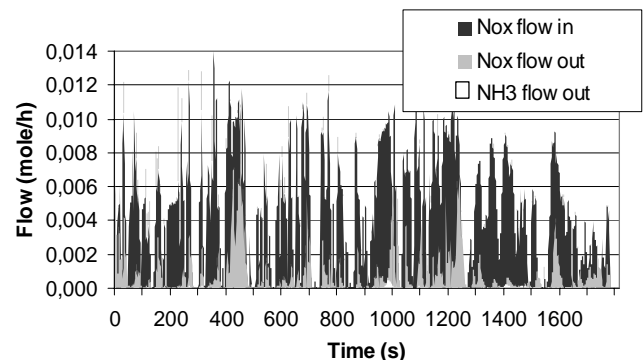

Figure 12. Example of NO_x reduction potential over an ETC cycle. 8.33 mole NO_x in, 1.51 mole NO_x out and 0.096 mole NH₃ out.

The results from several ETC tests are presented in Figure 13, where NO_x emissions and mean ammonia slip during the ETC cycle are plotted against the total amount of urea injected during the cycle.

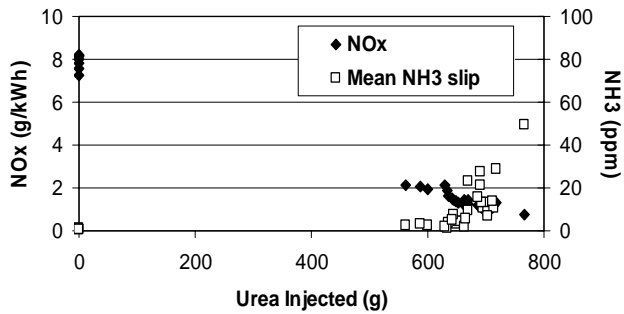

Figure 13. Summary of results of ETC cycles with DNX15 and DNX15-Pd catalysts.

It can be seen that with an acceptable mean ammonia slip of less than 5-7 ppm a conversion of 82-84% can be achieved that would be sufficient for the task.

As far as other emissions are concerned, the DNX15 and DNX15-Pd catalyst combination removes approximately 90% of the hydrocarbons but also more than 95% of the CO. SCR catalyst alone can remove hydrocarbons but with an increase in CO levels. This is due to the fact that the SCR catalyst is a good partial oxidation catalyst but is not good at completely oxidizing hydrocarbons to CO₂. The addition of the slip oxidation catalyst will lead to a complete oxidization of hydrocarbons and CO to CO₂. The addition of the slip oxidation catalyst leads to a formation of N₂O, which is not seen on a pure SCR catalyst.

A summary of ETC emission results with optimized strategy for the DNX15 and DNX-Pd catalysts is given in Table 2.

Table 2. ETC result using DNX15 and DNX15-Pd catalyst with optimized urea injection strategy .

Cycle	NOx	CO	HC	NH ₃	Urea/fuel
ETC	(g/kWh)			ppm ¹	%
w/o SCR	7.97	4.54	1.26	0.8	0
w SCR	1.37	0.13	0.12	4	7
Conv.	82.8	97.1	90.4		

¹⁾ Average ppm over the test cycle

ESC TESTS WITH DNX15 AND DNX15-PD CATALYSTS

Tests were run with the European Stationary Cycle. The ESC is a 13 mode stationary cycle having one idle mode, which is run for 4 minutes, and then the 12 other modes are run for 2 minutes each.

A high conversion of NOx could be achieved and the baseline emissions of 9.3 g NOx/kWh could be brought down to 1.53 g/kWh, 83.5 % conversion, with small NH₃ slip of the order of 3-4 ppm. The results from that ESC cycle are presented in Figure 14.

Like for the ETC the DNX15-DNX15-Pd catalyst also achieves high HC and CO reductions above 95%.

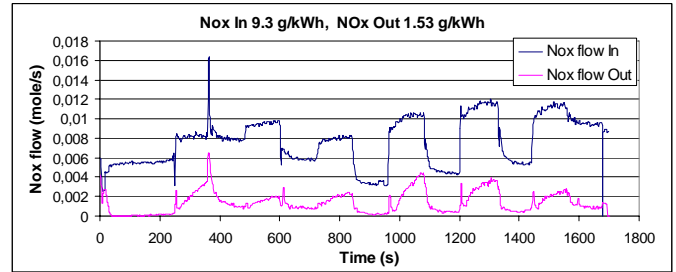

Figure 14 NOx emissions from ESC cycle

A summary of the ESC emission results with optimized strategy for the DNX15 and DNX-Pd catalysts is given in Table 3.

Table 3. ESC results using DNX15 and DNX15-Pd catalysts with optimized urea injection strategy.

Cycle	NOx	CO	HC	NH ₃	Urea/fuel
ESC	(g/kWh)			ppm ¹	%
w/o SCR	9.32	5.26	0.85	0.8	0
w SCR	1.53	0.07	0.04	3	7.7
Conv.	83.6	98.7	95.7		

¹⁾ Average ppm over the test cycle

EFFECT OF UREA-SCR CATALYST CELL DENSITY

The operating conditions used for choosing the catalyst design are those prevailing at maximum engine with high temperatures and high mass-flows. Under these conditions, the rate of reaction (and thus the conversion) is controlled by gas film whereby the catalyst activity is proportional to the geometric surface per liter of catalyst. Therefore, by increasing the cell density the catalyst volume can be reduced significantly. This is the reason why a new type of DNX urea-SCR catalyst with a cell density of 300 cpsi was developed. Since the walls of the channels in the catalyst consist of active material throughout the full wall thickness, the catalyst also has a high low-temperature activity.

In Figure 15 below, a relative comparison is made between two different catalysts, one with a cell density of 130 cpsi, which was used in the test described above, and one with the high cell density of 300 cpsi. It is seen that the high temperature as well as the low temperature activity of the catalyst increase substantially by increasing the cell density from 130 to 300 cpsi. As shown above 30 liters of the 130 cpsi catalyst was very close to have a NOx reduction capacity of more than 80% with a low ammonia slip, below 10 ppm. With the 300 cpsi Urea-SCR catalyst 20 liters of catalyst is required to achieve the desired conversion efficiency. With this novel catalyst, no oxidation catalyst will be needed.

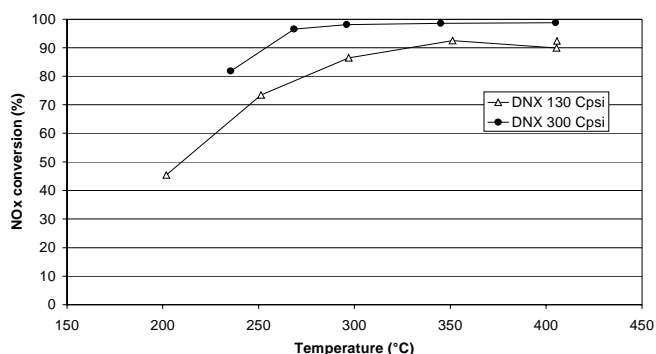

Figure 15. Comparison of stationary NO_x reduction activity between two Urea-SCR catalyst with different cell densities, 130 and 300 cpsi under the same experimental conditions.

CONCLUSION

Achievement of more than 80% of NO_x-reduction with ammonia slip below 10 ppm was demonstrated on a 12-liters HD diesel engine by using a slightly modified digital dosing pump type DME to control the urea injection. The injection system was shown to be precise and reliable, meaning that DME type meets the high demands to fluctuations in needed volume and reproducibility.

Extensive testing at transient conditions of 15 liters of DNX followed by 15 liters DNX-Pd showed that the high NO_x conversion of could be achieved with NH₃ slip below 10 ppm for both ETC and ESC driving cycles, see Table 2 and 3. The NO_x reduction was achieved together with very high reductions in HC and CO levels, above 90%.

The 45 liter DNX catalyst had the best NO_x reduction performance of all catalyst combinations. The 30 liters DNX catalyst was very close to achieving the target of NO_x reduction but had ammonia slip over the target level. Plain DNX also showed a high HC reduction at the expense of a small increase in the CO emissions like all previously pure Urea-SCR catalysts tested.

With the novel 300 cpsi Urea-SCR catalyst the volume can be reduced to 2/3 compared to the 130 cpsi catalyst, meaning the use of about 20 liters of SCR catalyst for a 12 liter 400 hp engine.

ACKNOWLEDGMENTS

Tine Ladefoged, Ingvard Bjørn, Erik Frost, Viggo Hansen and Svend-Erik Mikkelsen at Haldor Topsøe A/S.

REFERENCES

1. Havenith et al., "Entveichlung eines Verbrauchs-Optimierten Euro 5 Nfz-Dieselmotors mit Harnstoff-SCR-Abgasnach-behandlung.", VDA Technischer Kongress, 28. -29. Sept. 2000, Frankfurt.
2. Walker et al, "Development of an Ammonia/SCR NO_x Reduction System for a Heavy Duty Natural Gas Engine", SAE paper 921673.
3. Gabrielsson et al, Combined Silencers and Urea-SCR Systems for the Heavy-duty Diesel Vehicles for OEM and Retrofit Markets, SAE paper 2001-01-0517.
4. Havenith et al, "Transient Performance of a Urea deNO_x Catalyst for Low Emissions Heavy-Duty Diesel engines", SAE paper 970185.
5. Fritz et al, "On-Road Demonstrations of NO_x Emissions Control for Diesel Trucks with SINOX Urea SCR System", SAE paper 1999-01-0111
6. Gabrielsson et al, "Urea-SCR NO_x Removal Efficiency For a Diesel Engine in the Suggested European ETC Test Cycle", 32nd ISATA Conference, 14th – 18th June 1999 –Vienna- Austria

CONTACT

HALDOR TOPSØE A/S
 Pär Gabrielsson
 Nymollevvej 55
 DK-2800 Lyngby
 Denmark
 Phone +45-45272184
 Fax +45-45272999
 e-mail: pg@topsoe.dk
 Homepage : www.haldortopsoe.com

DENMARK

HALDOR TOPSØE A/S
P.O. Box 213
Nymøllevvej 55
DK-2800 Lyngby
Phone: +45-45 27 20 00
Telefax: +45-45 27 29 99

INDIA

HALDOR TOPSØE
INTERNATIONAL A/S
India Liaison Office
B-42 Panchsheel Enclave (1st Floor)
New Delhi 110 017
Phone: +91-11-5175 0081-85
Telefax: +91-11-5175 0202

JAPAN

HALDOR TOPSØE
INTERNATIONAL A/S
Tokyo Branch Office
Shiroyama JT Trust Tower, 33rd Floor
3-1, Toranomon 4-Chome
Minato-ku, Tokyo 105-6090
Phone: +81-3-5472-7501
Telefax: +81-3-5472-6633

**PEOPLE'S REPUBLIC
OF CHINA**

HALDOR TOPSØE
INTERNATIONAL A/S
Beijing Representative Office
Room 1008, Scitech Tower
22 Jianguomenwai Dajie
100004 Beijing
Phone: +86-10-6512 3620
Telefax: +86-10-6512 7381

RUSSIA

HALDOR TOPSØE A/S
Moscow Representative Office
Bryusov Street 11, 4th Floor
125009 Moscow
Phone: +7-095-229-6350
+7-095-956-3274
Telefax: +7-095-956-3275
ZAO HALDOR TOPSØE
42 Respublikanskaya
150040 Yaroslavl
Phone: +7-0852-730173
Telefax: +7-0852-252558

USA

HALDOR TOPSOE, INC.
17629, El Camino Real
Houston, TX 77058
Phone: +1-281-228-5000
Telefax: +1-281-228-5019
HALDOR TOPSOE, INC.
Refining Technology Division
770 The City Drive
Orange, CA 92868
Phone: +1-714-621-3800
Telefax: +1-714-748-4188

www.haldortopsoe.com